

БОЛЬШОЙ СКЛАД ЗАПЧАСТЕЙ В САНКТ-ПЕТЕРБУРГЕ

Для лодочных моторов Suzuki в наличии все ходовые запчасти, сервисные наборы, расходные материалы, оригинальные аксессуары, оригинальные и не оригинальные гребные винты, “ноги”, тросы для установки на лодку и многое другое.

Найдите в каталоге коды необходимых запчастей

и отправьте их список на Email: parts-katalog@yandex.ru

мы пришлём информацию о цене и наличии

Возможен самовывоз со склада в Санкт-Петербурге

или отправка EMS по России

Наш сайт: www.partskatalog.ru

Контактный телефон: +7 (981) 121-46-93

Особое внимание, обратите на модификацию двигателя. Сверьте серийный номер и скачайте «правильный» каталог запчастей. Не путайте старые моторы серии «Т» и новые серии «А».

SUZUKI

PARTS CATALOGUE

DF4/5/6

DF4
DF5
DF6



OUTBOARD MOTOR

P01

2012-6

1ST EDITION

PREFACE

When it becomes necessary to replace parts on SUZUKI OUTBOARD MOTORS, always use SUZUKI GENUINE PARTS which have passed a strict inspection which guarantees quality and performance.

This parts catalogue covers the list of all service parts for SUZUKI DF4/5/6 production start 2012.

INSTRUCTIONS FOR QUOTING THE CATALOGUE

1. DIMENSIONS

Dimensions of the parts in this catalogue are indicated in unit millimeters.

2. ABBREVIATIONS

Abbreviations used in this catalogue are as follows:

AR	: As required	NT	: Number of teeth
ASSY	: Assembly	OPT	: Optional
E. NO.	: Engine number	OS	: Over size
F. NO.	: Frame number	STD	: Standard
D	: Diameter of material	T	: Thickness
ID	: Inside diameter	US	: Under size
OD	: Outside diameter	W	: Width
L	: Length	W/	: With
LH(PORT)	: Left hand side	S. L	: Transom type
RH(STBD)	: Right hand side	SUS	: Stainless steel
~123456	: Up to E. NO. 00402F-123456		
123456~	: From E. NO. 00402F-123456		
12 x 34 x 5.6.....	Figures in the description column		
	show the dimensions of parts.		
ID OD T(or W, L)			

→12345-56781 (Parts No.) : indicates that the parts number was changed to 12345-56781 and the new parts are interchangeable with the former ones but the former ones are not interchangeable with new ones.

←12345-56781 (Parts No.) : indicates that the former and new parts are interchangeable with each other and both are usable.

3. INNER PARTS OF ASSEMBLY

Part name with a dot (.) in front as shown in the description column indicates the component of the assembly also available individually.

4. MODIFICATION NOTICE

A parts bulletin will be sent to you on all occasions when changes in parts occur, including interchangeable modifications between new parts and old ones.

5. NOTE

- 5-1. There are some different parts from those of production models among spare parts for the administrative reasons and common use of them with other models.
- 5-2. In respect of rubber hoses and vinyl tubes, please be sure to use them by cutting off according to the length mentioned on parts catalogue or what is actually required on the vehicle.
- 5-3. Note that the drawings on the illustration page are for ready reference of spare parts number, not to be used as an assembly manual.
When assembling, use "SUZUKI SERVICE MANUAL".

6. MODEL NAME AND ENGINE NUMBER

MODEL	DESTINATION	TYPE	TRANSOM	ENGINE No.
DF4L	P01	00402F	S, L	00402F-310001~
DF5L	P01	00502F	S, L	00502F-310001~
DF6L	P01	00602F	S, L	00602F-310001~

MILLIMETER → INCH CONVERSION CHART

	0	1	2	3	4	5	6	7	8	9
00	.000	.039	.079	.118	.157	.197	.236	.276	.315	.354
10	.394	.433	.472	.512	.551	.591	.630	.669	.709	.748
20	.787	.827	.866	.906	.945	.984	1.024	1.063	1.102	1.142
30	1.181	1.220	1.260	1.299	1.339	1.378	1.417	1.457	1.496	1.535
40	1.575	1.614	1.654	1.693	1.732	1.772	1.811	1.850	1.890	1.929
50	1.969	2.008	2.047	2.087	2.126	2.165	2.205	2.214	2.283	2.323
60	2.362	2.402	2.441	2.480	2.520	2.559	2.598	2.638	2.677	2.717
70	2.756	2.795	2.835	2.874	2.913	2.953	2.992	3.031	3.071	3.110
80	3.150	3.189	3.228	3.268	3.307	3.346	3.386	3.425	3.465	3.504
90	3.543	3.583	3.622	3.661	3.701	3.740	3.780	3.819	3.858	3.898

How to read

	0	1	2	3	4
00
10
20	0.906	...
30

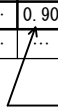
 23 millimeters equal 0.906 inch

Contents are subject to change without notice or obligation.

FIG.1DF4_5_8_P01_013_001
CYLINDER HEAD**FIG.2**DF4_5_8_P01_013_002
CYLINDER HEAD**FIG.3**DF4_5_8_P01_013_003
CYLINDER HEAD**FIG.4**DF4_5_8_P01_013_004
CYLINDER BLOCK**FIG.5**DF4_5_8_P01_013_005
CRANKSHAFT**FIG.6**DF4_5_8_P01_013_006
INTAKE MANIFOLD**FIG.7**DF4_5_8_P01_013_007
INTAKE MANIFOLD**FIG.8**DF4_5_8_P01_013_008
INTAKE MANIFOLD

FIG.9DF4_5_8_P01_013_009
CARBURETOR**FIG.10**DF4_5_8_P01_013_010
CARBURETOR**FIG.11**DF4_5_8_P01_013_011
CARBURETOR**FIG.12**DF4_5_8_P01_013_012
FUEL PUMP**FIG.13**DF4_5_8_P01_013_013
FUEL PUMP**FIG.14**DF4_5_8_P01_013_014
FUEL PUMP**FIG.15**DF4_5_8_P01_013_015
WATER PUMP**FIG.16**DF4_5_8_P01_013_016
RECOIL STARTER

FIG.25

DF4_5_8_P01_013_025
GEAR CASE

FIG.26

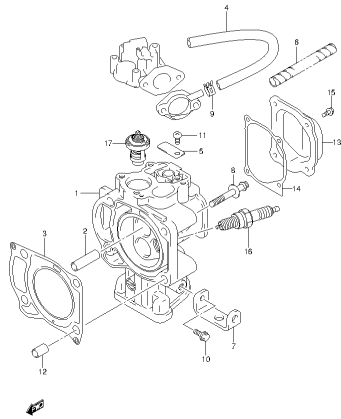
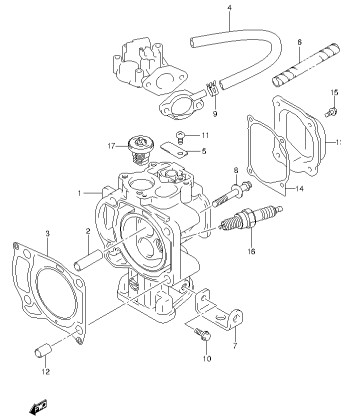
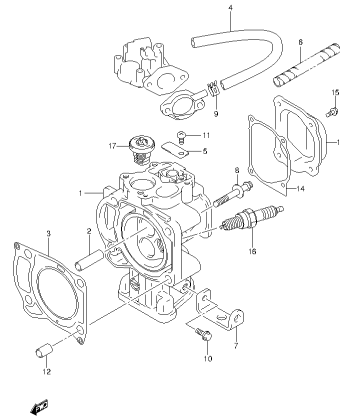
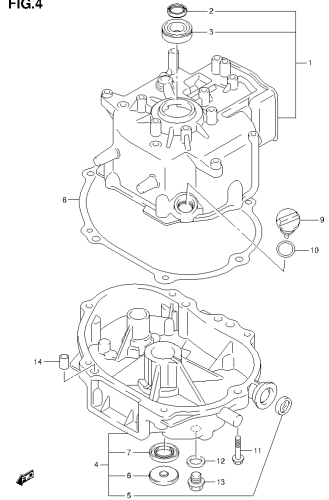
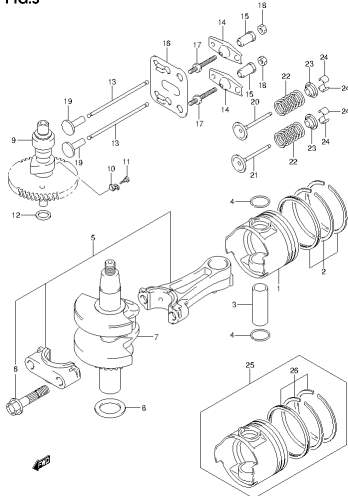
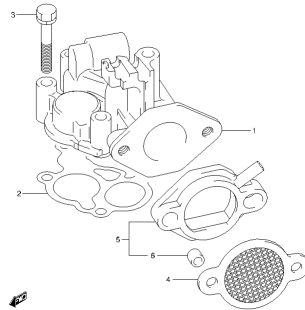
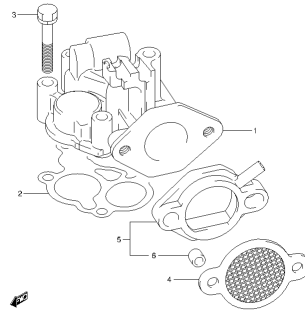
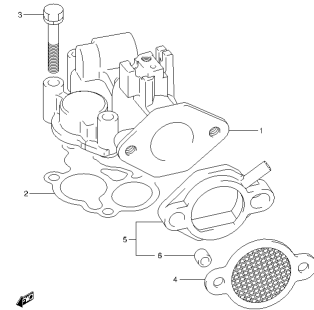
DF4_5_8_P01_013_026
LOWER COVER

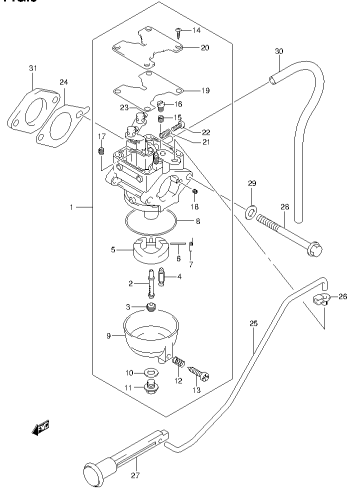
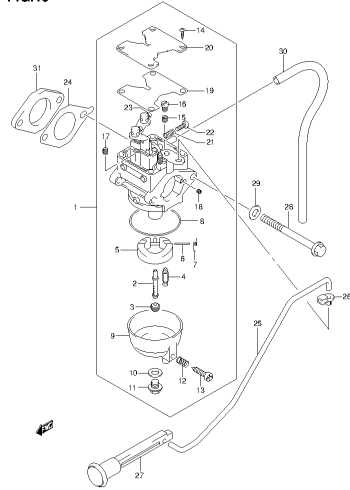
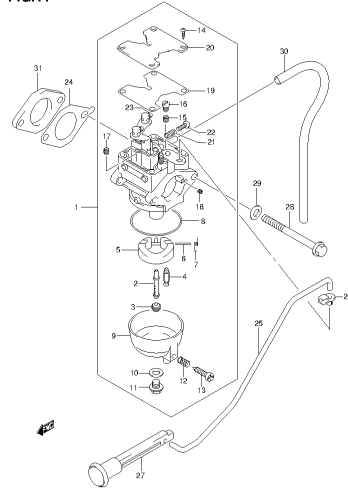
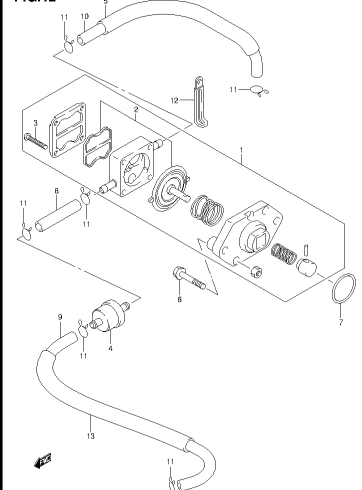
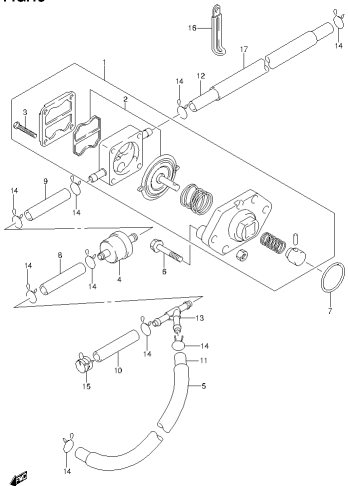
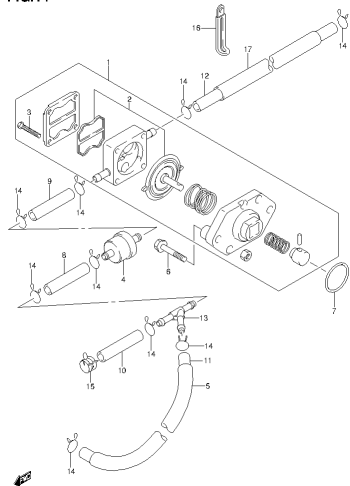
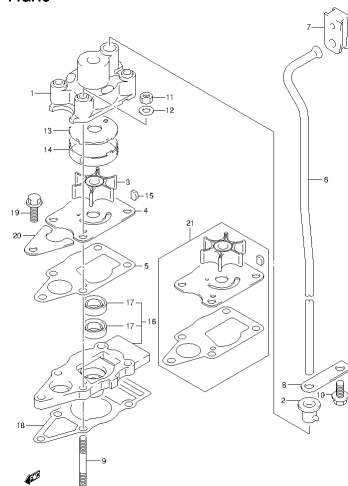
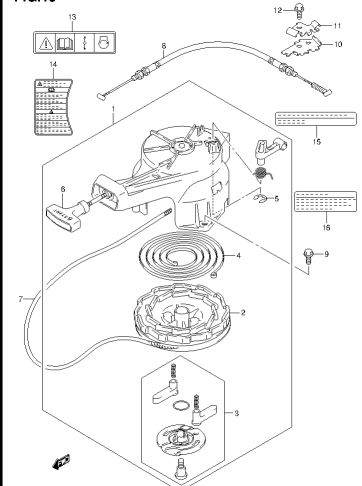
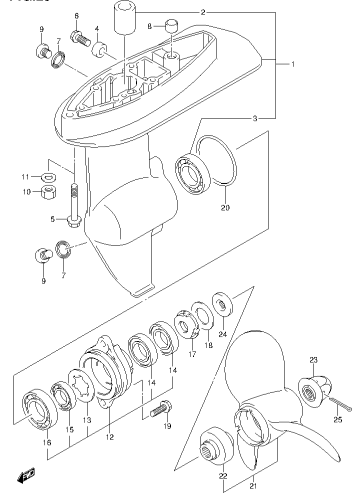
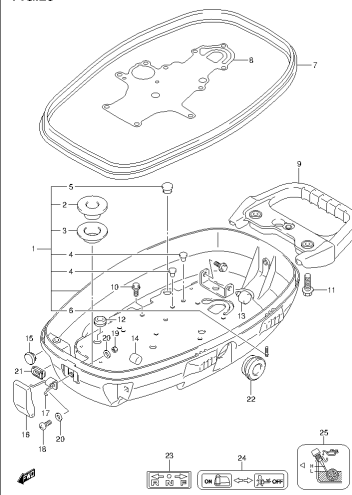
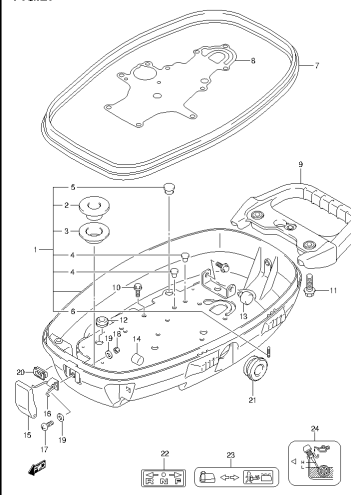
FIG.27

DF4_5_8_P01_013_027
LOWER COVER

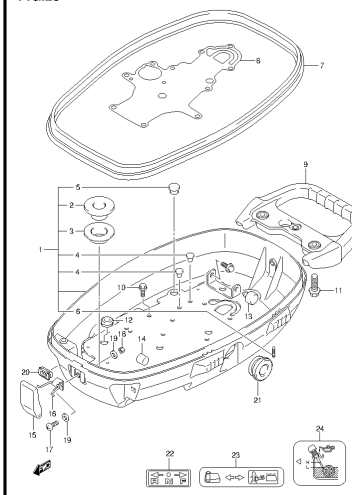
FIG.28

DF4_5_8_P01_013_028
LOWER COVER

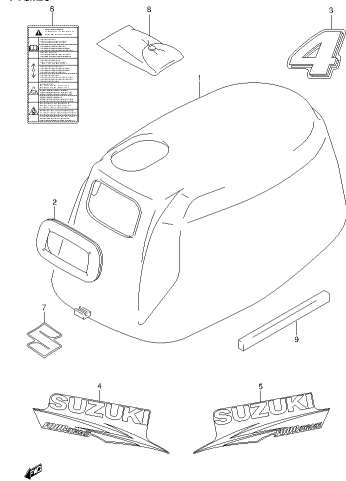
FIG.29

DF4_5_8_P01_013_029
ENGINE COVER

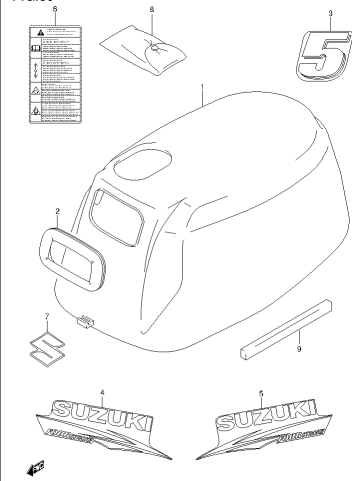
FIG.30

DF4_5_8_P01_013_030
ENGINE COVER

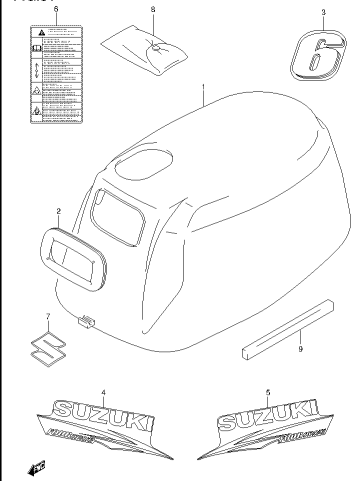
FIG.31

DF4_5_8_P01_013_031
ENGINE COVER

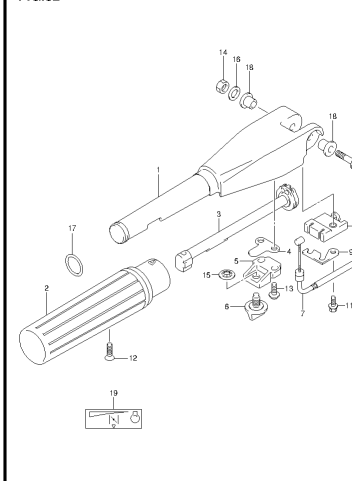
FIG.32

DF4_5_8_P01_013_032
TILLER HANDLE

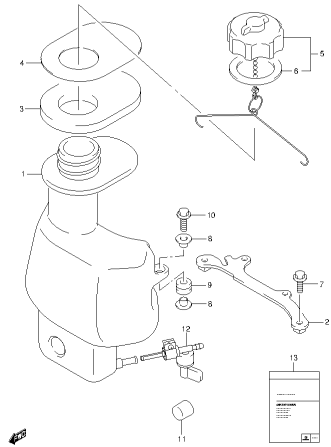
FIG.33

DF4_5_8_P01_013_035
FUEL TANK

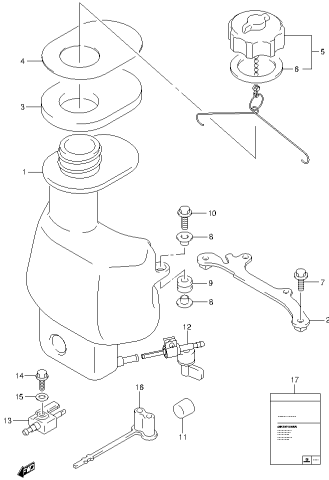
FIG.34

DF4_5_8_P01_013_034
FUEL TANK

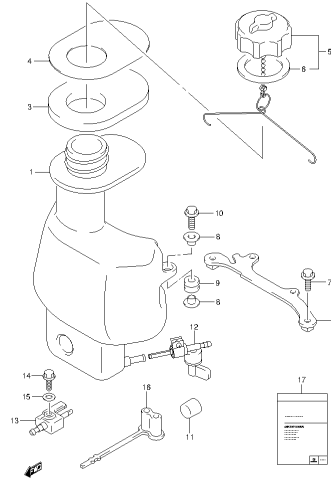
FIG.35

DF4_5_8_P01_013_035
FUEL TANK

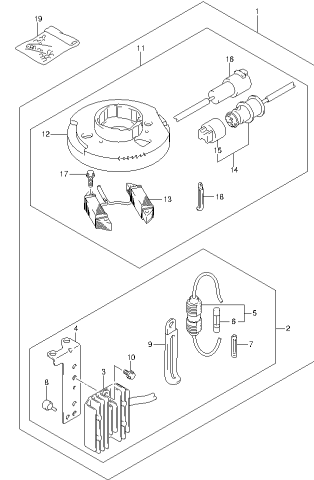
FIG.36

DF4_5_8_P01_013_036
OPT / ELECTRICAL

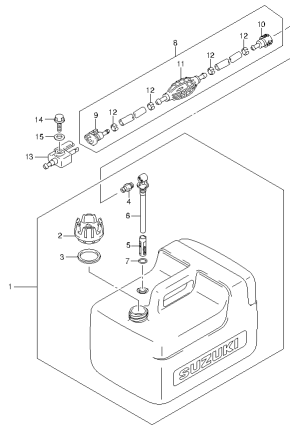
FIG.37

DF4_5_8_P01_013_037
OPT / FUEL TANK (RESIN)

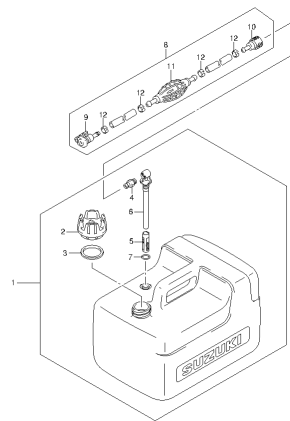
FIG.38

DF4_5_8_P01_013_038
OPT / FUEL TANK (RESIN)

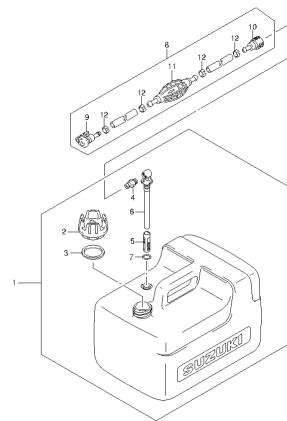
FIG.39

DF4_5_8_P01_013_039
OPT / FUEL TANK (RESIN)

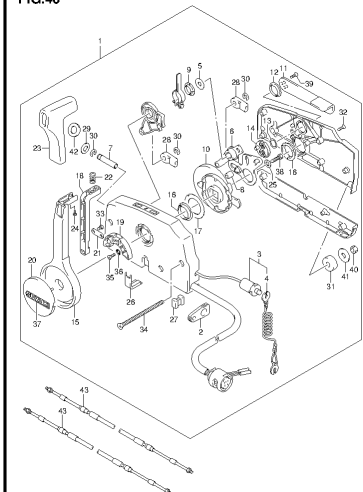
FIG.40

DF4_5_8_P01_013_040
OPT / REMOTE CONTROL

FIG.41

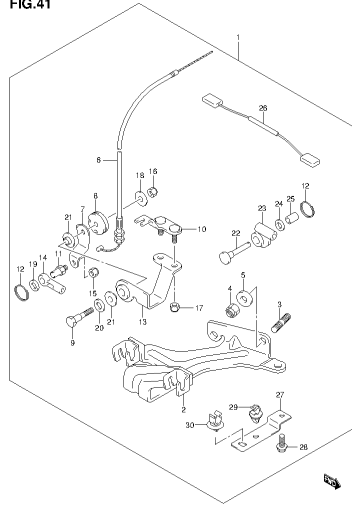

DE-LS_3_F01_013_041
OPTIEMOGON PARTS SET

FIG.1

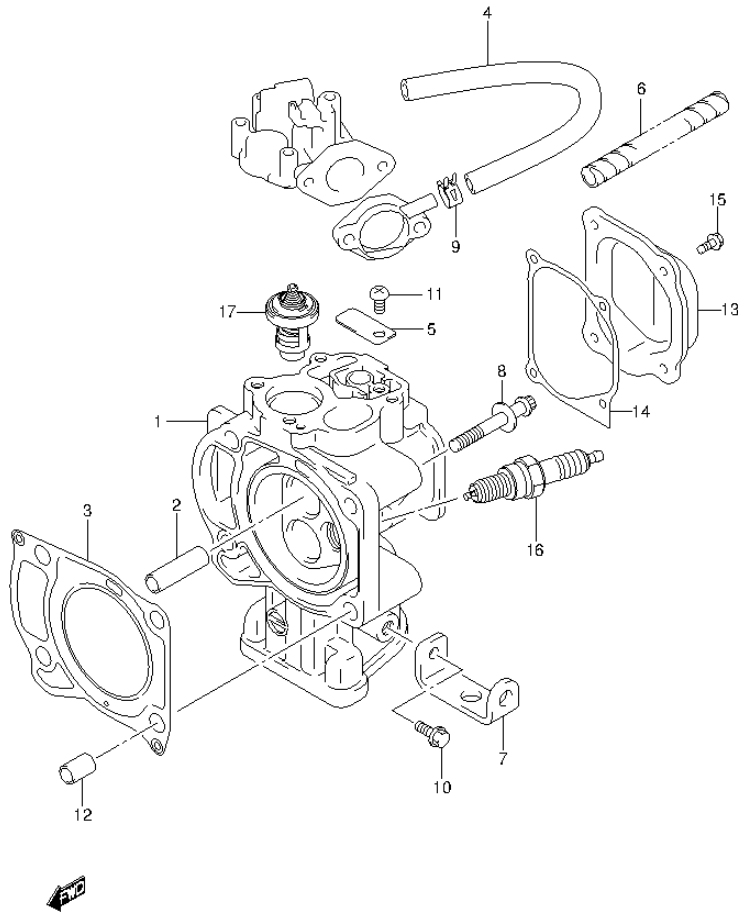

FIG.1 (1-B-2) CYLINDER HEAD (DF4 P01)

REF NO.	PART NO.	DESCRIPTION	Q'TY	REMARKS
1	11110-91J30-000	HEAD, CYLINDER	1	
2	11114-90980-000	GUIDE, VALVE	1	OPT@
3	11141-91JL0-000	GASKET, CYLINDER HEAD	1	
4	11174-91J00-000	HOSE, BREATHER	1	
5	11452-91J00-000	VALVE, REED	1	
6	18498-91JL0-180	PROTECTOR	1	
7	61827-91J00-000	HOLDER, LOWER COVER	1	
8	11117-91JL0-000	BOLT, CYLINDER HEAD	4	
9	09401-11424-000	CLIP	1	
10	01550-06167-000	BOLT	1	
11	02112-0612A-000	SCREW	1	
12	04211-11169-000	PIN	2	
13	11171-91J00-000	COVER, CYLINDER HEAD	1	
14	11189-91J00-000	GASKET, CYLINDER HEAD COVER	1	
15	01550-06167-000	BOLT	4	
16	09482-00L04-000	SPARK PLUG (NGK, CPR6EA-9)	1	
17	17670-91J10-000	THERMOSTAT (50C)	1	

FIG.2

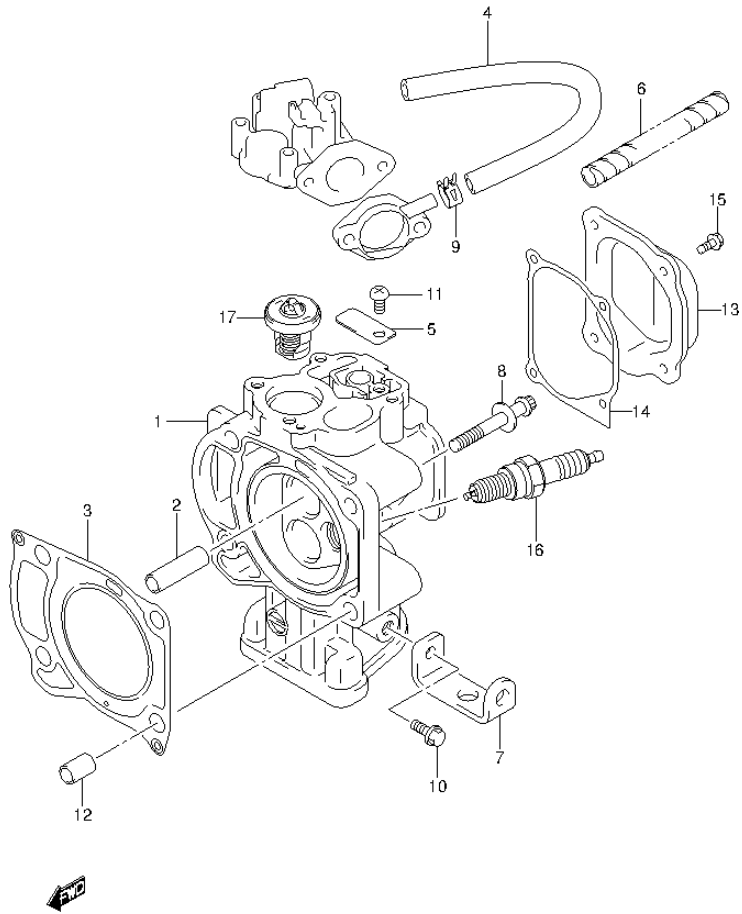

FIG.2 (1-B-3) CYLINDER HEAD (DF5 P01)

REF NO.	PART NO.	DESCRIPTION	Q'TY	REMARKS
1	11110-91J30-000	HEAD, CYLINDER	1	
2	11114-90980-000	GUIDE, VALVE	1	OPT
3	11141-91JL0-000	GASKET, CYLINDER HEAD	1	
4	11174-91J00-000	HOSE, BREATHER	1	
5	11452-91J00-000	VALVE, REED	1	
6	18498-91JL0-180	PROTECTOR	1	
7	61827-91J00-000	HOLDER, LOWER COVER	1	
8	11117-91JL0-000	BOLT, CYLINDER HEAD	4	
9	09401-11424-000	CLIP	1	
10	01550-06167-000	BOLT	1	
11	02112-0612A-000	SCREW	1	
12	04211-11169-000	PIN	2	
13	11171-91J00-000	COVER, CYLINDER HEAD	1	
14	11189-91J00-000	GASKET, CYLINDER HEAD COVER	1	
15	01550-06167-000	BOLT	4	
16	09482-00L04-000	SPARK PLUG (NGK, CPR6EA-9)	1	
17	17670-91J20-000	THERMOSTAT (42C)	1	

FIG.3

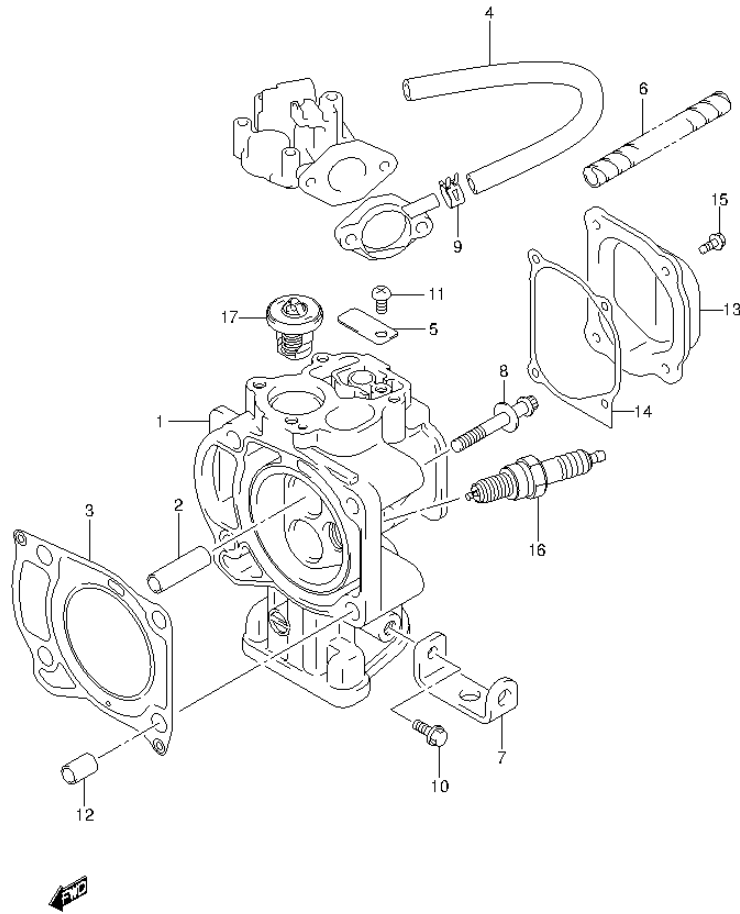

FIG.3 (1-B-4) CYLINDER HEAD (DF6 P01)

REF NO.	PART NO.	DESCRIPTION	Q'TY	REMARKS
1	11110-91J30-000	HEAD, CYLINDER	1	
2	11114-90980-000	GUIDE, VALVE	1	OPT
3	11141-91JL0-000	GASKET, CYLINDER HEAD	1	
4	11174-91J00-000	HOSE, BREATHER	1	
5	11452-91J00-000	VALVE, REED	1	
6	18498-91JL0-180	PROTECTOR	1	
7	61827-91J00-000	HOLDER, LOWER COVER	1	
8	11117-91JL0-000	BOLT, CYLINDER HEAD	4	
9	09401-11424-000	CLIP	1	
10	01550-06167-000	BOLT	1	
11	02112-0612A-000	SCREW	1	
12	04211-11169-000	PIN	2	
13	11171-91J00-000	COVER, CYLINDER HEAD	1	
14	11189-91J00-000	GASKET, CYLINDER HEAD COVER	1	
15	01550-06167-000	BOLT	4	
16	09482-00L04-000	SPARK PLUG (NGK, CPR6EA-9)	1	
17	17670-91J20-000	THERMOSTAT (42C)	1	

FIG.4

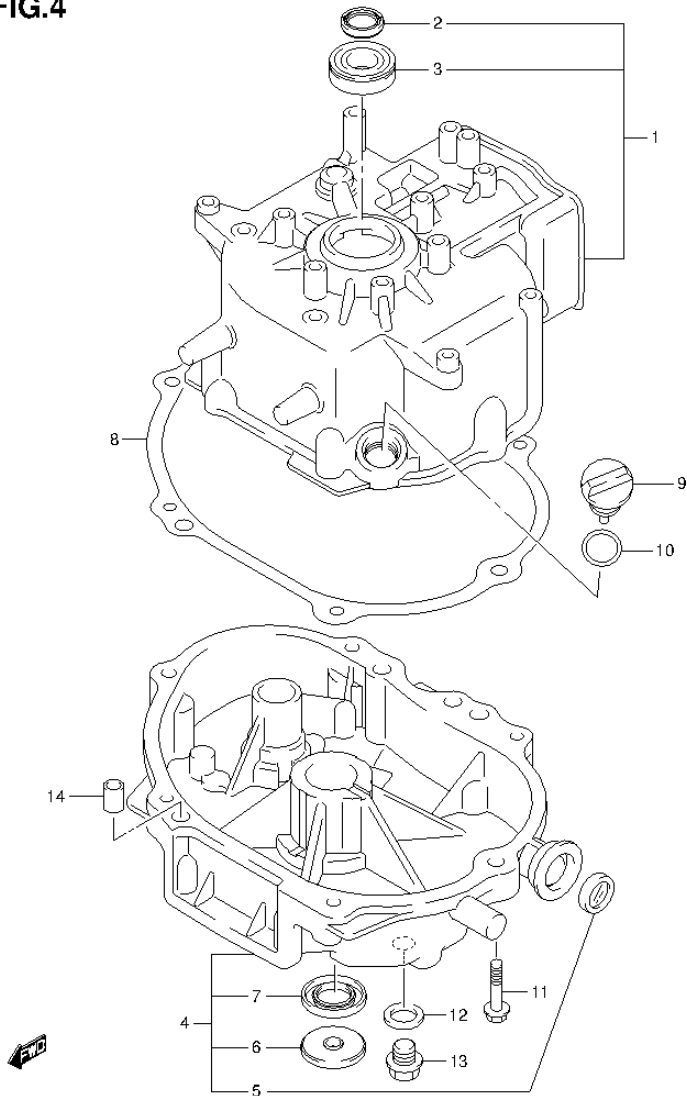
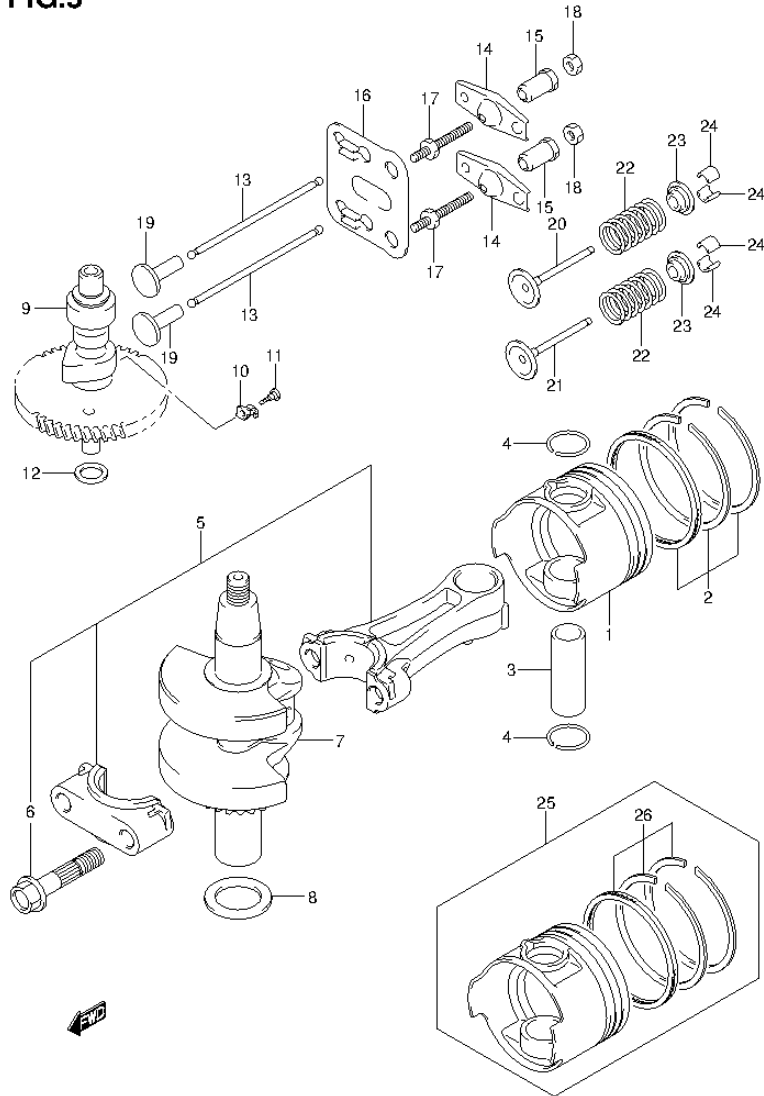

FIG.4 (1-B-5) CYLINDER BLOCK

REF NO.	PART NO.	DESCRIPTION	Q'TY	REMARKS
1	11200-91J20-000	BLOCK ASSY, CYLINDER	1	
2	09283-25098-000	.OIL SEAL (25X35X5)	1	
3	09262-25003-000	.BEARING (25X52X15)	1	
4	11300-91J20-000	CASE ASSY, CRANKSHAFT	1	
5	11971-91J01-000	.LENS, OIL LEVEL FILTER	1	
6	09283-10L01-000	.OIL SEAL	1	
7	09283-25L04-000	.OIL SEAL (25X45X5)	1	LOWER
8	11351-91J00-000	GASKET, CRANKCASE	1	
9	11381-91J10-000	GAUGE, OIL LEVEL (YELLOW)	1	
10	09280-15007-000	O RING (D:2.4,ID:15.8)	1	
11	01550-06307-000	BOLT	6	
12	09168-10022-000	GASKET (10X17X1.5)	1	
13	09248-10008-000	PLUG (10X7.5)	1	
14	04211-09149-000	PIN	2	

FIG.5



DF4_5_6_P01_013_005
CRANKSHAFT

FIG.5 (1-B-6) CRANKSHAFT

REF NO.	PART NO.	DESCRIPTION	Q'TY	REMARKS
1	12111-91J01-0B0	PISTON	1	
2	12140-91J10-000	RING SET, PISTON	1	
3	12151-90900-000	PIN, PISTON	1	
4	09381-18002-000	CIRCLIP	2	
5	12160-91JL0-000	CONNROD ASSY	1	
6	12163-91JL0-000	.BOLT CONNROD	2	
7	12200-91JL0-000	CRANKSHAFT ASSY	1	
8	08211-25361-000	WASHER	1	
9	12711-91J20-000	CAMSHAFT (NT:46)	1	
10	12951-91J00-000	CAM, DECOMPRESSION	1	
11	09106-02001-000	BOLT (2X9,8)	1	
12	08211-17251-000	WASHER	1	
13	12894-90711-000	ROD, PUSH	2	
14	12961-90900-000	ARM, ROCKER	2	
15	12962-91JL0-000	PIVOT	2	
16	12966-91J00-000	GUIDE, ROD	1	
17	09108-06126-000	STUD BOLT	2	
18	09140-06021-000	NUT	2	
19	12891-87C00-000	TAPPET	2	
20	12911-91J00-000	VALVE, INTAKE	1	
21	12915-91J00-000	VALVE, EXHAUST	1	
22	12921-91J00-000	SPRING, VALVE	2	
23	12931-89L00-000	RETAINER, VALVE SPRING	2	
24	12932-24400-000	COTTER, VALVE	4	
25	12100-91J10-050	PISTON SET (OS:0.50)	1	OPT
26	12140-91J10-050	.RING SET, PISTON (OS:0.50)	1	OPT

DF4_5_6_P01_013

FIG.6

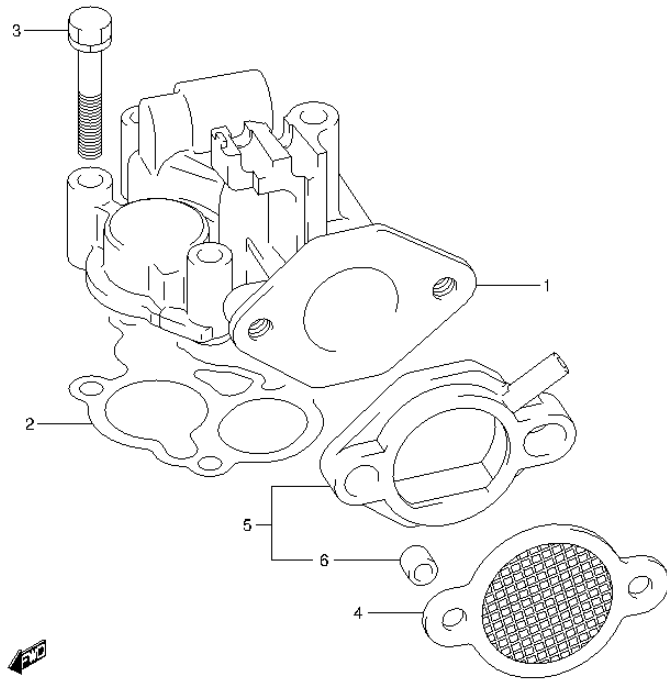

FIG.6 (1-B-7) INTAKE MANIFOLD (DF4 P01)

REF NO.	PART NO.	DESCRIPTION	Q'TY	REMARKS
1	13111-91J90-000	MANIFOLD, INTAKE	1	
2	13119-91J00-000	GASKET, INLET MANIFOLD	1	
3	01570-06357-000	BOLT	4	
4	13710-91J20-000	ARRESTER, FLAME	1	
5	13720-91J30-000	HOLDER, FLAME ARRESTER	1	
6	09180-06310-000	.SPACER (6.5X10X10)	2	

FIG.7

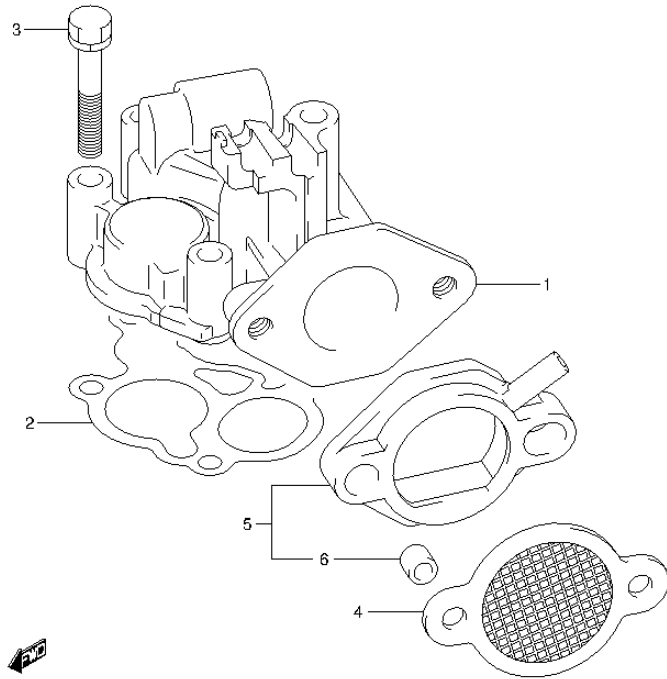

FIG.7 (1-B-8) INTAKE MANIFOLD (DF5 P01)

REF NO.	PART NO.	DESCRIPTION	Q'TY	REMARKS
1	13111-91J90-000	MANIFOLD, INTAKE	1	
2	13119-91J00-000	GASKET, INLET MANIFOLD	1	
3	01570-06357-000	BOLT	4	
4	13710-91J20-000	ARRESTER, FLAME	1	
5	13720-91J30-000	HOLDER, FLAME ARRESTER	1	
6	09180-06310-000	.SPACER (6.5X10X10)	2	

FIG.8

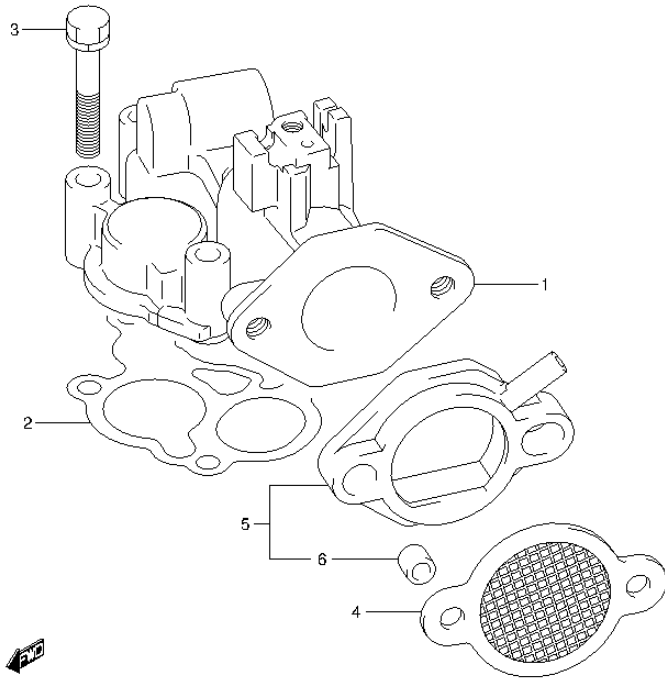

FIG.8 (1-B-9) INTAKE MANIFOLD (DF6 P01)

REF NO.	PART NO.	DESCRIPTION	Q'TY	REMARKS
1	13111-91J80-000	MANIFOLD, INTAKE	1	
2	13119-91J00-000	GASKET, INLET MANIFOLD	1	
3	01570-06357-000	BOLT	4	
4	13710-91J20-000	ARRESTER, FLAME	1	
5	13720-91J30-000	HOLDER, FLAME ARRESTER	1	
6	09180-06310-000	.SPACER (6.5X10X10)	2	

FIG.9

FIG.9 (1-B-10) CARBURETOR (DF4 P01)

REF NO.	PART NO.	DESCRIPTION	Q'TY	REMARKS
1	13200-91JQ0-000	CARBURETOR	1	
2	13236-91J50-000	.NOZZLE, MAIN	1	
3-1	09491-50L01-000	.JET, MAIN (50)	1	
3-2	09491-52L01-000	.JET, MAIN (52)	1	
3-3	09491-54L01-000	.JET, MAIN (54)	1	
4	13371-91J20-000	.VALVE, NEEDLE	1	
5	13250-97J00-000	.FLOAT	1	
6	13254-97J00-000	.PIN, FLOAT	1	
7	13268-97J30-000	.SPRING	1	
8	13251-97J00-000	.GASKET	1	
9	13245-97J00-000	.CHAMBER, FLOAT	1	
10	13249-97J00-000	.GASKET	1	
11	13247-97J00-000	.SCREW	1	
12	13268-97J10-000	.SPRING	1	
13	13616-97J00-000	.SCREW	1	
14	13267-97J00-000	.SCREW	4	
15-1	09492-32011-000	.JET, PILOT (32)	1	
15-2	09492-34004-000	.JET, PILOT (34)	1	
15-3	09492-36L01-000	.JET, PILOT (36)	1	
16	13267-97J10-000	.SCREW	1	
17	09493-22L01-000	.JET, MAIN AIR (110)	1	
18	09493-95L01-000	.JET, SLOW AIR (95)	1	
19	13249-97J10-000	.GASKET	1	
20	13248-97J00-000	.PLATE	1	
21	13268-97J20-000	.SPRING	1	
22	13534-97J10-000	.SCREW	1	
23	13267-97J20-000	.SCREW	2	

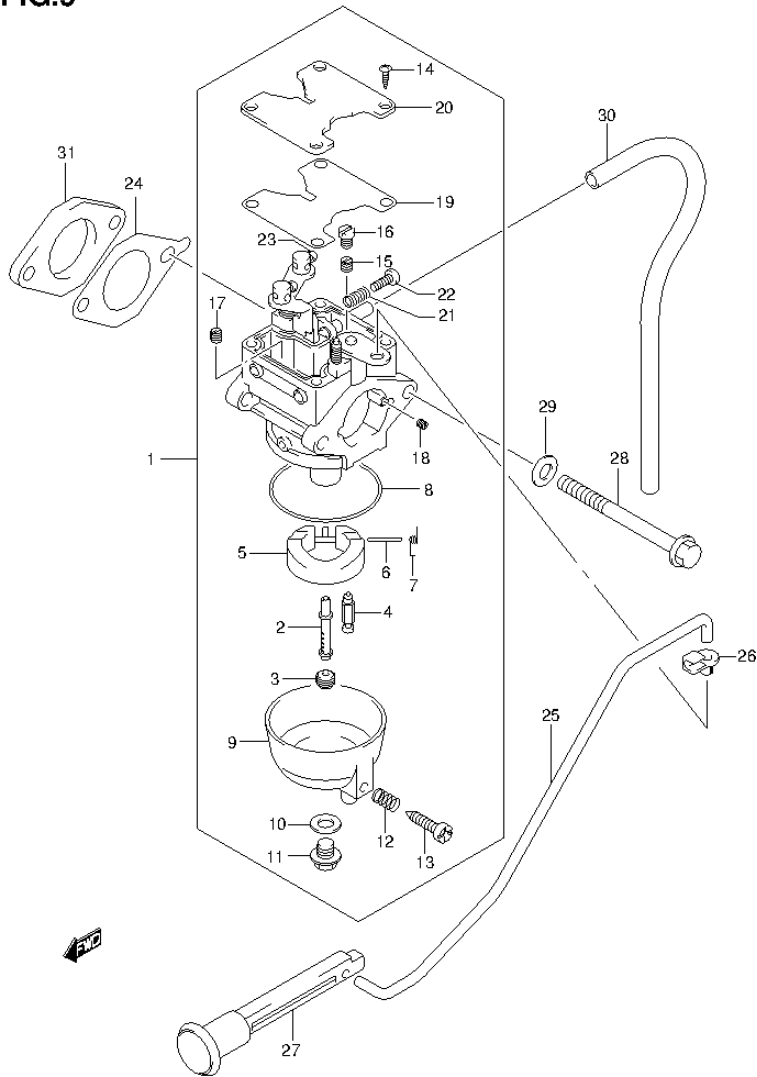

FIG.10

FIG.10 (1-B-13) CARBURETOR (DF5 P01)

REF NO.	PART NO.	DESCRIPTION	Q'TY	REMARKS
24	13125-91J10-000	GASKET, CARBURETOR	2	
25	13413-91JL0-000	ROD, CHOKE	1	
26	13436-91J00-000	CONNECTOR, CHOKE ROD	1	
27	13631-91J00-000	KNOB, CHOKE	1	
28	01547-06857-000	BOLT	2	
29	08322-01067-000	WASHER	2	
30	09355-50105-600	HOSE (5X10X600)	1	L:600->230
31	13124-91JL0-000	INSULATOR, CARBURETOR	1	

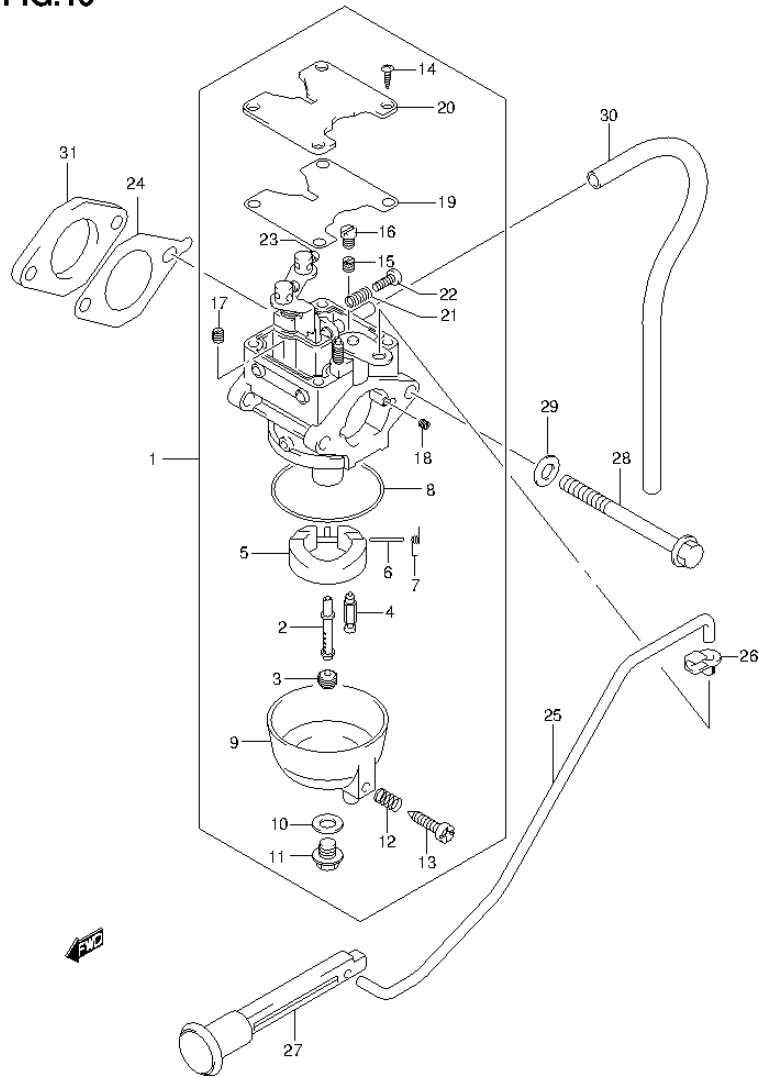

FIG.11

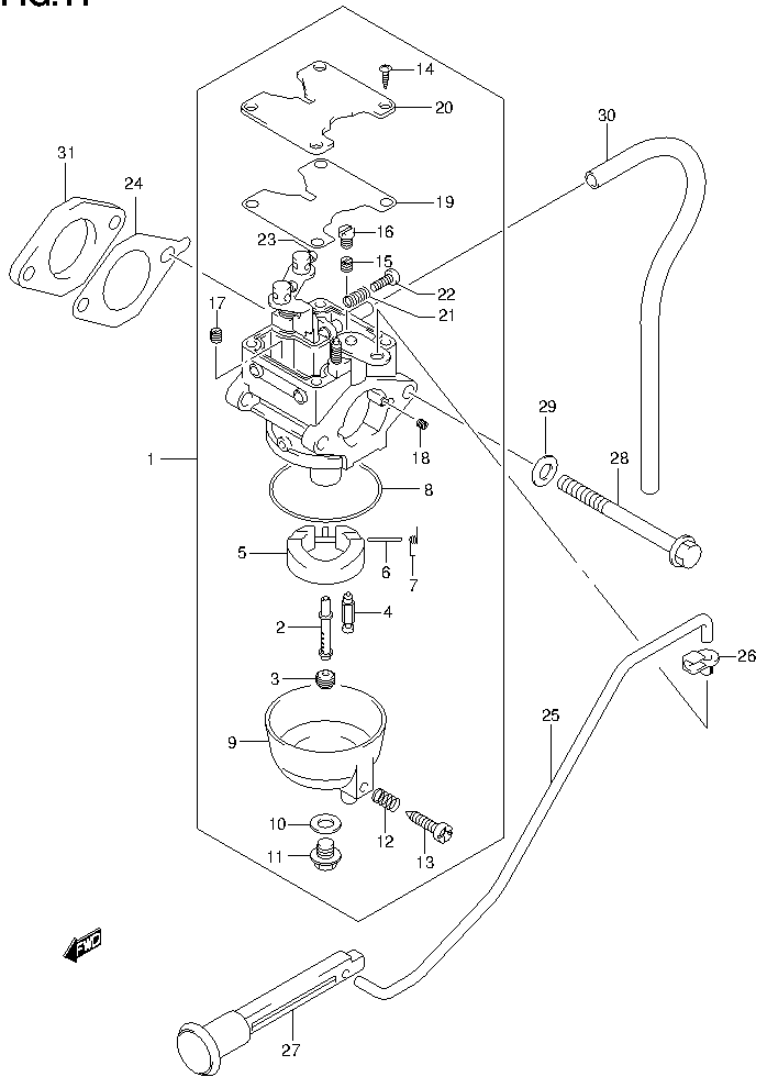

FIG.11 (1-B-14) CARBURETOR (DF6 P01)

REF NO.	PART NO.	DESCRIPTION	Q'TY	REMARKS
1	13200-91JS0-000	CARBURETOR	1	
2	13236-91J40-000	.NOZZLE, MAIN	1	
3-1	09491-68006-000	.JET, MAIN (68)	1	
3-2	09491-70018-000	.JET, MAIN (70)	1	
3-3	09491-66005-000	.JET, MAIN (66)	1	
4	13371-91J20-000	.VALVE, NEEDLE	1	
5	13250-97J00-000	.FLOAT	1	
6	13254-97J00-000	.PIN, FLOAT	1	
7	13268-97J30-000	.SPRING	1	
8	13251-97J00-000	.GASKET	1	
9	13245-97J00-000	.CHAMBER, FLOAT	1	
10	13249-97J00-000	.GASKET	1	
11	13247-97J00-000	.SCREW	1	
12	13268-97J10-000	.SPRING	1	
13	13616-97J00-000	.SCREW	1	
14	13267-97J00-000	.SCREW	4	
15-1	09492-34004-000	.JET, PILOT (34)	1	
15-2	09492-36L01-000	.JET, PILOT (36)	1	
15-3	09492-38L01-000	.JET, PILOT (38)	1	
16	13267-97J10-000	.SCREW	1	
17	09493-21L01-000	.JET, MAIN AIR (105)	1	
18	09493-95L01-000	.JET, SLOW AIR (95)	1	
19	13249-97J10-000	.GASKET	1	
20	13248-97J00-000	.PLATE	1	
21	13268-97J20-000	.SPRING	1	
22	13534-97J10-000	.SCREW	1	
23	13267-97J20-000	.SCREW	2	

FIG.11

FIG.11 (1-B-15) CARBURETOR (DF6 P01)

REF NO.	PART NO.	DESCRIPTION	Q'TY	REMARKS
24	13125-91J10-000	GASKET, CARBURETOR	2	
25	13413-91JL0-000	ROD, CHOKE	1	
26	13436-91J00-000	CONNECTOR, CHOKE ROD	1	
27	13631-91J00-000	KNOB, CHOKE	1	
28	01547-06857-000	BOLT	2	
29	08322-01067-000	WASHER	2	
30	09355-50105-600	HOSE (5X10X600)	1	L:600->230
31	13124-91JL0-000	INSULATOR, CARBURETOR	1	

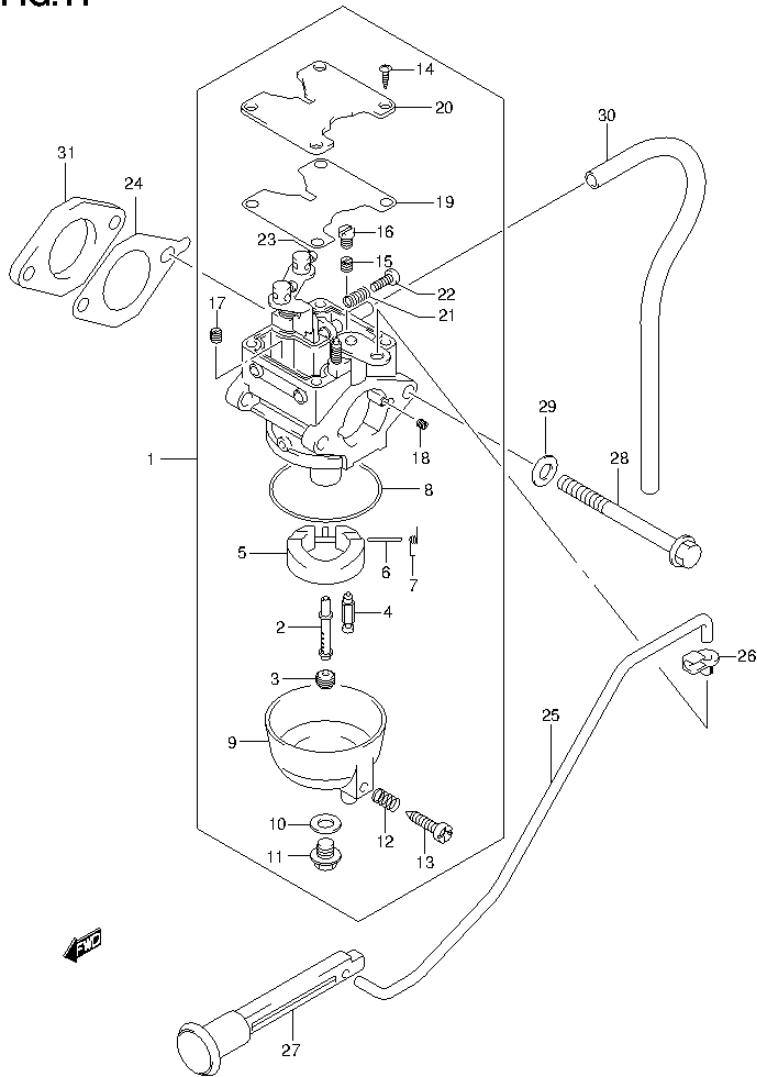

FIG.12

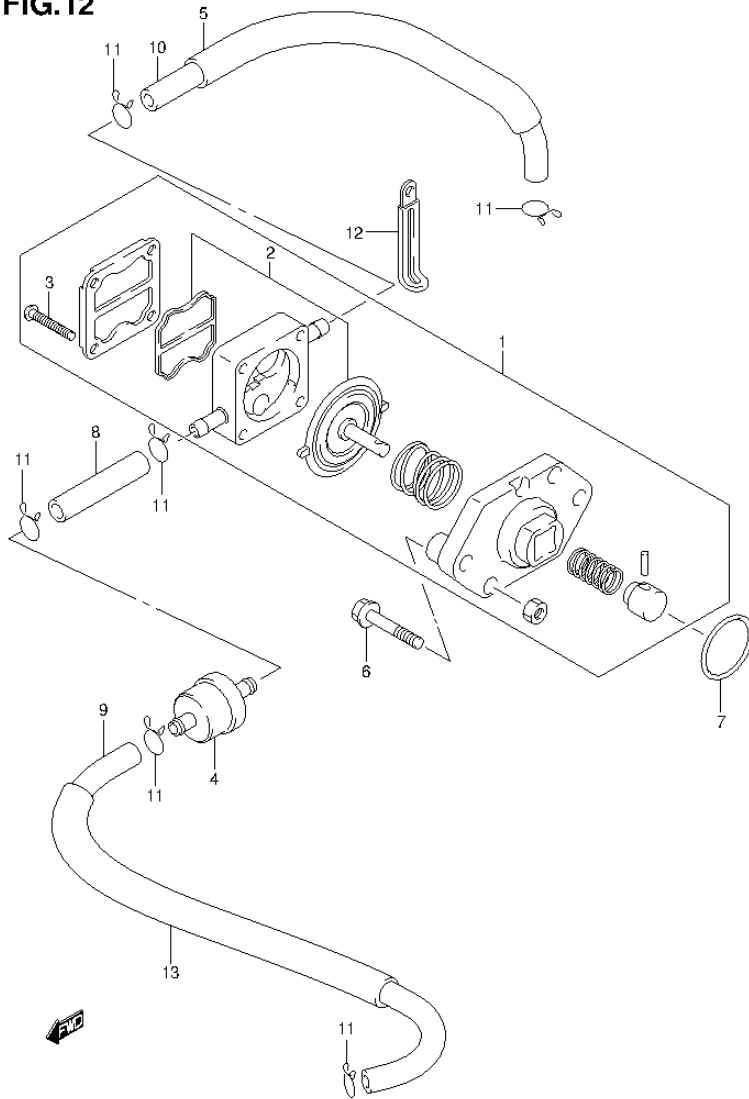

FIG.12 (1-C-2) FUEL PUMP (DF4 P01)

REF NO.	PART NO.	DESCRIPTION	Q'TY	REMARKS
1	15100-91J02-000	PUMP ASSY, FUEL	1	
2	15170-91J01-000	.DIAPHRAGM SET	1	
3	15251-91J00-000	.SCREW	4	
4	15410-98500-000	FILTER	1	
5	18498-94JL0-130	PROTECTOR (L:130)	1	
6	01550-06307-000	BOLT	2	
7	09280-27006-000	O RING (D:2, ID:27.5)	1	
8	09343-50L01-040	HOSE (5X10X40)	1	
9	15191-91JM0-000	HOSE, FUEL (TANK TO FILTER)	1	
10	09343-50L01-300	HOSE (5X10X300)	1	
11	59412-91J00-000	CLIP	6	
12	29404-93J10-000	CLAMP	1	
13	18498-94JL0-100	PROTECTOR (L:100)	1	

FIG.13

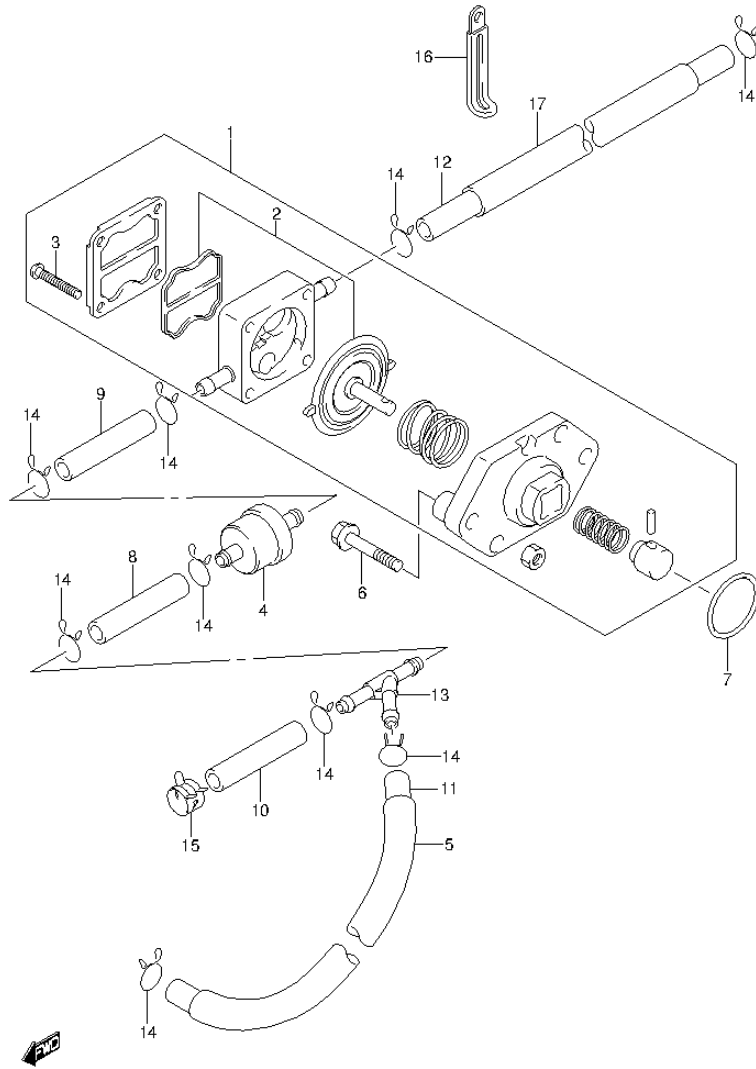

FIG.13 (1-C-3) FUEL PUMP (DF5 P01)

REF NO.	PART NO.	DESCRIPTION	Q'TY	REMARKS
1	15100-91J02-000	PUMP ASSY, FUEL	1	
2	15170-91J01-000	.DIAPHRAGM SET	1	
3	15251-91J00-000	.SCREW	4	
4	15410-98500-000	FILTER, FUEL	1	
5	18498-94JL0-100	PROTECTOR (L:100)	1	
6	01550-06307-000	BOLT	2	
7	09280-27006-000	O RING (D:2, ID:27.5)	1	
8	09343-50L01-040	HOSE (5X10X40)	1	
9	09343-50L01-040	HOSE (5X10X40)	1	
10	15192-91JL0-000	HOSE, FUEL (CONN TO ELB)	1	
11	15191-91JL0-000	HOSE, FUEL (TANK, TO FILTER)	1	
12	09343-50L01-300	HOSE (5X10X300)	1	
13	09367-06007-000	3 WAY	1	
14	59412-91J00-000	CLIP	9	
15	09401-11422-000	CLIP	1	
16	29404-93J10-000	CLAMP	1	
17	18498-94JL0-130	PROTECTOR (L:130)	1	

FIG.14

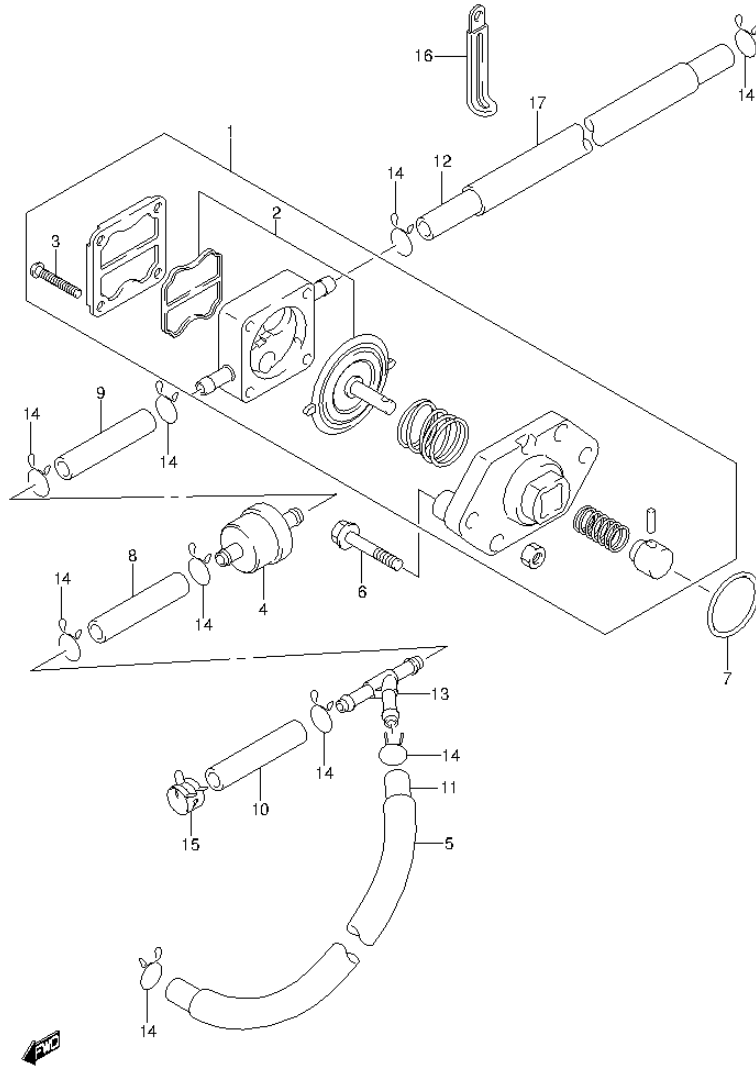

FIG.14 (1-C-4) FUEL PUMP (DF6 P01)

REF NO.	PART NO.	DESCRIPTION	Q'TY	REMARKS
1	15100-91J02-000	PUMP ASSY, FUEL	1	
2	15170-91J01-000	.DIAPHRAGM SET	1	
3	15251-91J00-000	.SCREW	4	
4	15410-98500-000	FILTER, FUEL	1	
5	18498-94JL0-100	PROTECTOR (L:100)	1	
6	01550-06307-000	BOLT	2	
7	09280-27006-000	O RING (D:2, ID:27.5)	1	
8	09343-50L01-040	HOSE (5X10X40)	1	
9	09343-50L01-040	HOSE (5X10X40)	1	
10	15192-91JL0-000	HOSE, FUEL (CONN TO ELB)	1	
11	15191-91JL0-000	HOSE, FUEL (TANK, TO FILTER)	1	
12	09343-50L01-300	HOSE (5X10X300)	1	
13	09367-06007-000	3 WAY	1	
14	59412-91J00-000	CLIP	9	
15	09401-11422-000	CLIP	1	
16	29404-93J10-000	CLAMP	1	
17	18498-94JL0-130	PROTECTOR (L:130)	1	

FIG.15

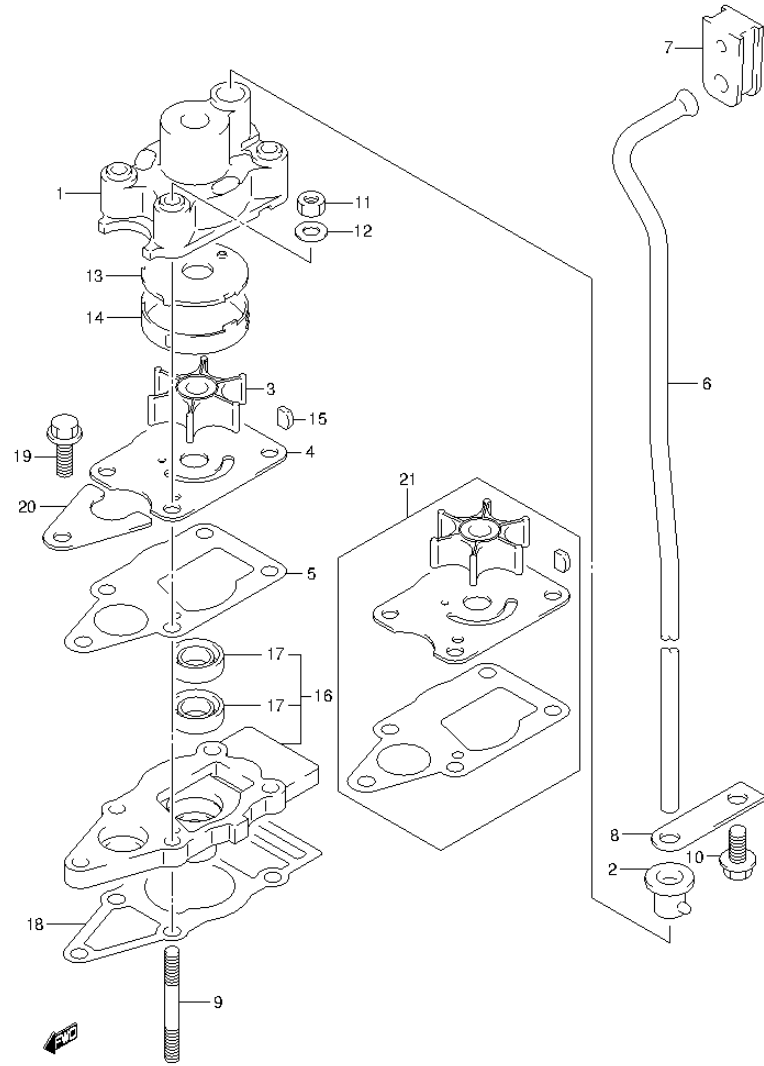

FIG.15 (1-C-5) WATER PUMP

REF NO.	PART NO.	DESCRIPTION	Q'TY	REMARKS
1	17410-91JL0-000	CASE ASSY, WATER PUMP	1	
2	17415-98501-000	GROMMET, WATER PUMP CASE	1	
3	17461-985M0-000	IMPELLER, WATER PUMP	1	
4	17471-98610-000	PANEL, PUMP CASE UNDER	1	
5	17472-91J00-000	GASKET, PUMP CASE PANEL	1	
6-1	17561-91JN0-000	TUBE, WATER (S)	1	W/TRANSOM(S)
6-2	17561-91JP0-000	TUBE, WATER (L)	1	W/TRANSOM(L)
7	17563-91J01-000	GROMMET, WATER TUBE UPPER	1	
8	17564-98600-000	GUIDE, WATER TUBE	1	
9	09108-06146-000	STUD BOLT	4	
10	09116-06225-000	BOLT (6X16)	1	
11	29141-93J00-000	NUT	4	
12	09160-06082-000	WASHER (6.5X13X1.0)	4	
13	17412-91JL0-000	PANEL, WATER PUMP CASE UPPER	1	
14	17413-91JL0-000	SLEEVE, WATER PUMP CASE	1	
15	09420-03002-000	KEY	1	
16	56130-91J20-000	HOUSING ASSY, DRIVE SHAFT BRG	1	
17	09282-10008-000	.OIL SEAL (10X21X4.5)	2	
18	56132-91J00-000	GASKET, DRIVE SHAFT HOUSING	1	
19	09116-06229-000	BOLT (6X25)	1	
20	25215-98601-000	STOPPER, SHIFT ROD GUIDE	1	
21	17400-98661-000	KIT, WATER PUMP REPAIR	1	OPT

FIG.16

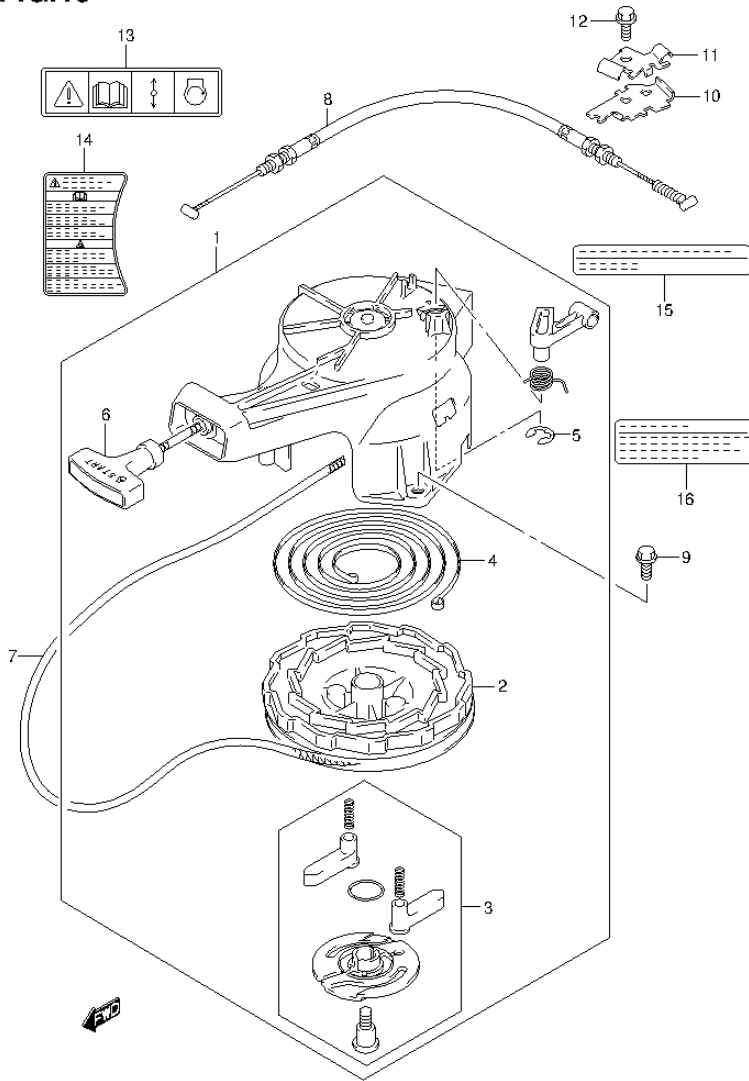

FIG.16 (1-C-6) RECOIL STARTER

REF NO.	PART NO.	DESCRIPTION	Q'TY	REMARKS
1	18100-91JL2-000	STARTER ASSY, RECOIL	1	
2	18120-91JL0-000	.REEL	1	
3	18130-98130-000	.RATCHET SET	1	
4	18142-92920-000	.SPRING, SPIRAL	1	
5	18178-98310-000	.CIRCLIP	1	
6	18210-98130-000	.GRIP ASSY	1	
7	99000-81157-50M	ROPE	1	OPT L:50000->1200
8	18290-91J01-000	CABLE, NSI	1	
9	09103-06048-000	BOLT (6X20)	3	
10	19183-91JL0-000	HOLDER, THROTTLE CABLE LOWER	1	
11	19183-91JM0-000	HOLDER, THROTTLE CABLE UPPER	1	
12	01550-06167-000	BOLT	1	
13	69711-93E10-000	LABEL, S.I.G.P	1	
14	61472-91J30-000	LABEL, RECOIL STARTER	1	
15	61493-91J00-000	LABEL, CLEARANCE	1	
16	61494-91J00-000	LABEL, OIL	1	

FIG.17

FIG.17 (1-C-7) OIL PUMP

REF NO.	PART NO.	DESCRIPTION	Q'TY	REMARKS
1	16131-91J00-000	ROTOR, OIL PUMP INNER	1	
2	16132-91J00-000	ROTOR, OIL PUMP OUTER	1	
3	16161-91J00-000	PLATE, OIL PUMP ROTOR	1	
4	16171-91J00-000	HOLDER, OIL PUMP PLATE	1	
5	16510-91J00-000	FILTER ASSY	1	

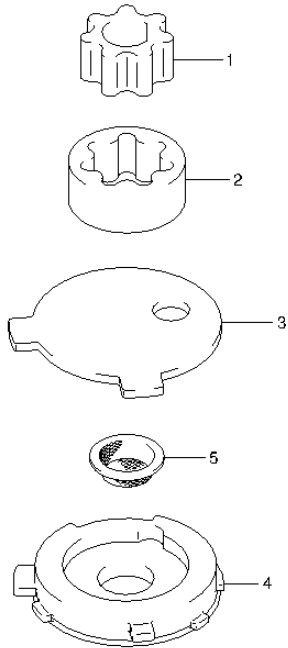

FIG.18

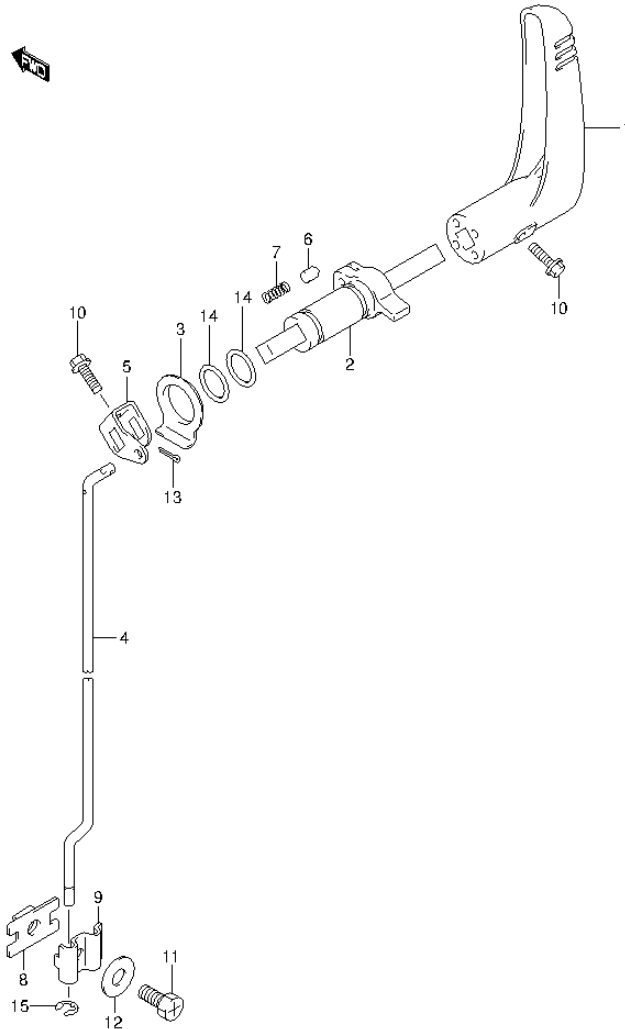

FIG.18 (1-C-8) CLUTCH LEVER

REF NO.	PART NO.	DESCRIPTION	Q'TY	REMARKS
1	21110-91JL0-000	LEVER, CLUTCH	1	
2	21120-91JL0-000	PLATE, CLUTCH NOTCH	1	
3	21216-91J00-000	SPACER, CLUTCH SHAFT	1	
4	23111-91J01-000	ROD, CLUTCH	1	
5	23211-91J00-000	ARM, CLUTCH ROD	1	
6	23212-91J00-000	PIN, CLUTCH NOTCH	1	
7	23213-91J00-000	SPRING, CLUTCH NOTCH	1	
8	23310-91J00-000	CONNECTOR, CLUTCH ROD NO.1	1	
9	23321-91J00-000	CONNECTOR, CLUTCH ROD NO.2	1	
10	09116-06227-000	BOLT (6X20)	2	
11	09128-06014-000	BOLT (6X20)	1	
12	09160-06145-000	WASHER (6.2X19X3)	1	
13	09204-01002-000	PIN	1	
14	09280-16005-000	O RING (D:2.4,ID:15.8)	2	
15	09383-04002-000	E RING	1	

FIG.19

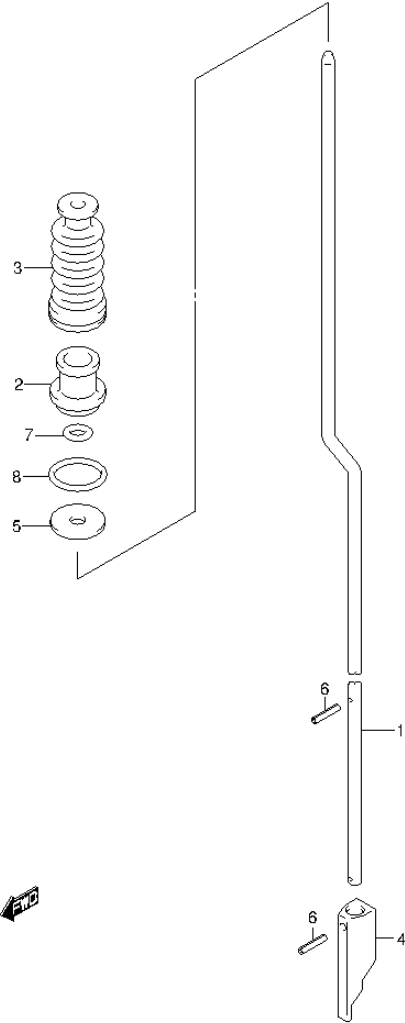
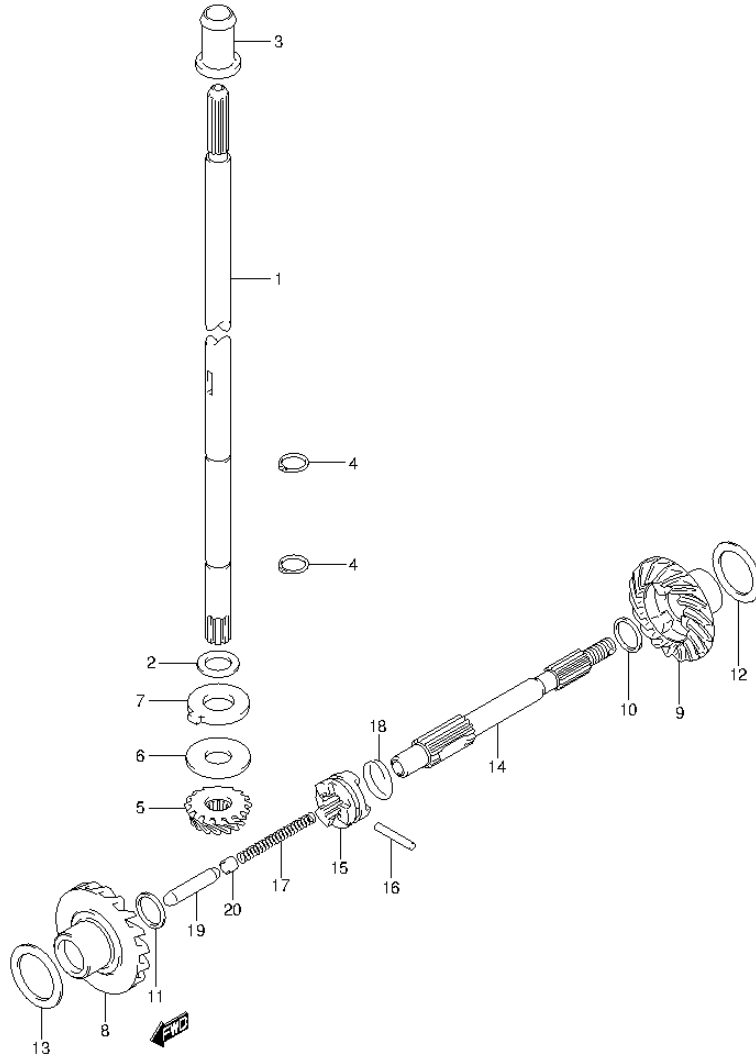

FIG.19 (1-C-9) SHIFT ROD

REF NO.	PART NO.	DESCRIPTION	Q'TY	REMARKS
1-1	25111-91J21-000	ROD, SHIFT (S)	1	W/TRANSOM(S)
1-2	25111-91J31-000	ROD, SHIFT (L)	1	W/TRANSOM(L)
2	25211-98601-000	GUIDE, SHIFT ROD	1	
3	25222-91JL0-000	BOOT, SHIFT ROD	1	
4	25311-91J01-000	CAM, SHIFT ROD	1	
5	09160-05501-000	WASHER (5.5X20X1.2)	1	
6	09205-02004-000	SPRING PIN (2.5X12)	2	
7	09280-05008-000	O RING (D:2.9,ID:4.8)	1	
8	09280-15007-000	O RING (D:2.4,ID:15.8)	1	

FIG.20



DF4_5_6_P01_013_020
DRIVE SHAFT

FIG.20 (1-C-10) DRIVE SHAFT

REF NO.	PART NO.	DESCRIPTION	Q'TY	REMARKS
1-1	57111-91J20-000	SHAFT, DRIVE (S)	1	W/TRANSOM(S)
1-2	57111-91J30-000	SHAFT, DRIVE (L)	1	W/TRANSOM(L)
2	09181-10156-000	SHIM (10X16X1.5)	1	
3	57130-91JL0-000	BUSH, DRIVE SHAFT	1	W/TRANSOM(L)
4	09380-10003-000	CIRCLIP	2	
5	57311-91J00-000	PINION (NT:12)	1	
6-1	09160-10088-000	WASHER (10X24X1.7)	1	PINION ADJ
6-2	09160-10089-000	WASHER (10X24X1.8)	1	PINION ADJ
6-3	09160-10090-000	WASHER (10X24X1.9)	1	PINION ADJ
6-4	09160-10091-000	WASHER (10X24X2)	1	PINION ADJ
6-5	09160-10092-000	WASHER (10X24X2.1)	1	PINION ADJ
7	09166-12L01-000	WASHER	1	
8	57510-91J00-000	GEAR, FORWARD (NT:23)	1	
9	57521-91J00-000	GEAR, REVERSE (NT:23)	1	
10-1	09181-12008-000	SHIM (12X16X0.6)	1	PROP SFT REV
10-2	09160-12070-000	WASHER (12X16X0.8)	1	PROP SFT REV
10-3	09181-12111-000	SHIM (12X16X1)	1	PROP SFT REV
11	09181-12111-000	SHIM (12X16X1)	1	PROP SFT FWD
12-1	09181-20159-000	SHIM (20X28X0.6)	1	REV GEAR
12-2	09181-20160-000	SHIM (20X28X0.7)	1	REV GEAR
12-3	09181-20162-000	SHIM (20X28X0.8)	1	REV GEAR
12-4	09181-20164-000	SHIM (20X28X0.9)	1	REV GEAR
12-5	09181-20167-000	SHIM (20X28X1)	1	REV GEAR
13-1	09181-20162-000	SHIM (20X28X0.8)	1	FWD GEAR
13-2	09181-20164-000	SHIM (20X28X0.9)	1	FWD GEAR
13-3	09181-20167-000	SHIM (20X28X1)	1	FWD GEAR
13-4	09181-20172-000	SHIM (20X28X1.1)	1	FWD GEAR
13-5	09181-20176-000	SHIM (20X28X1.2)	1	FWD GEAR

DF4_5_6_P01_013

FIG.20

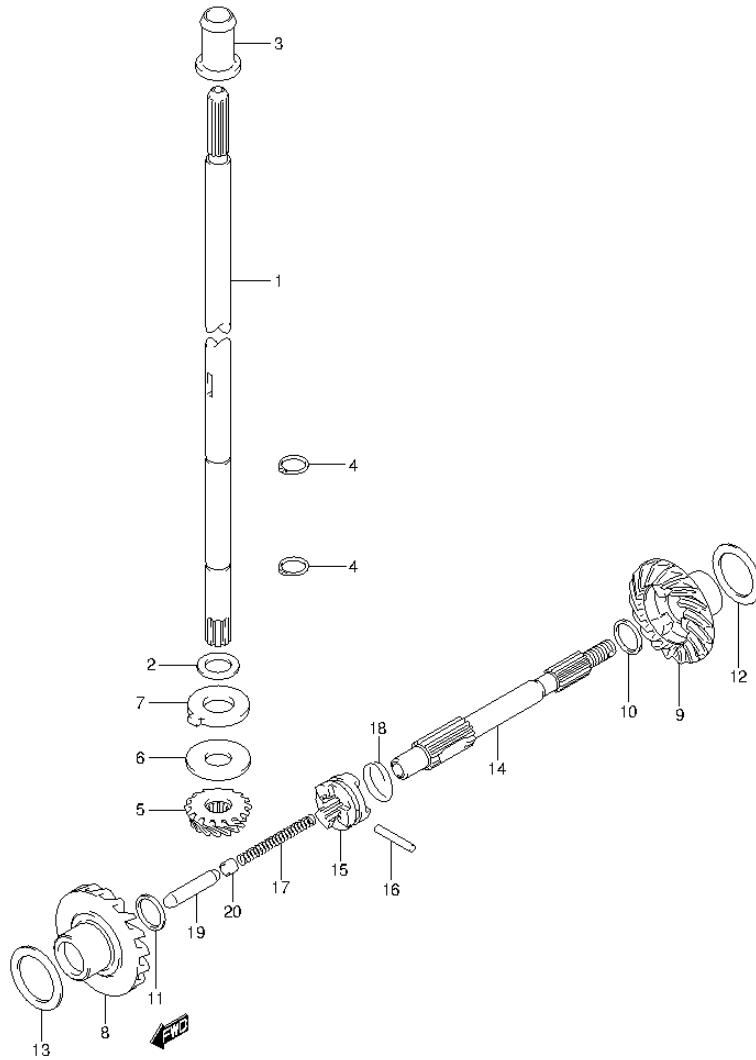

FIG.20 (1-C-11) DRIVE SHAFT

REF NO.	PART NO.	DESCRIPTION	Q'TY	REMARKS
14	57611-91J10-000	SHAFT, PROPELLER	1	
15	57621-986L0-000	SHIFTER, CLUTCH DOG	1	
16	09202-04016-000	PIN	1	
17	09440-05039-000	SPRING	1	
18	09440-24007-000	SPRING	1	
19	57631-98601-000	ROD, PUSH	1	
20	57632-98500-000	PIN, PUSH	1	

FIG.21

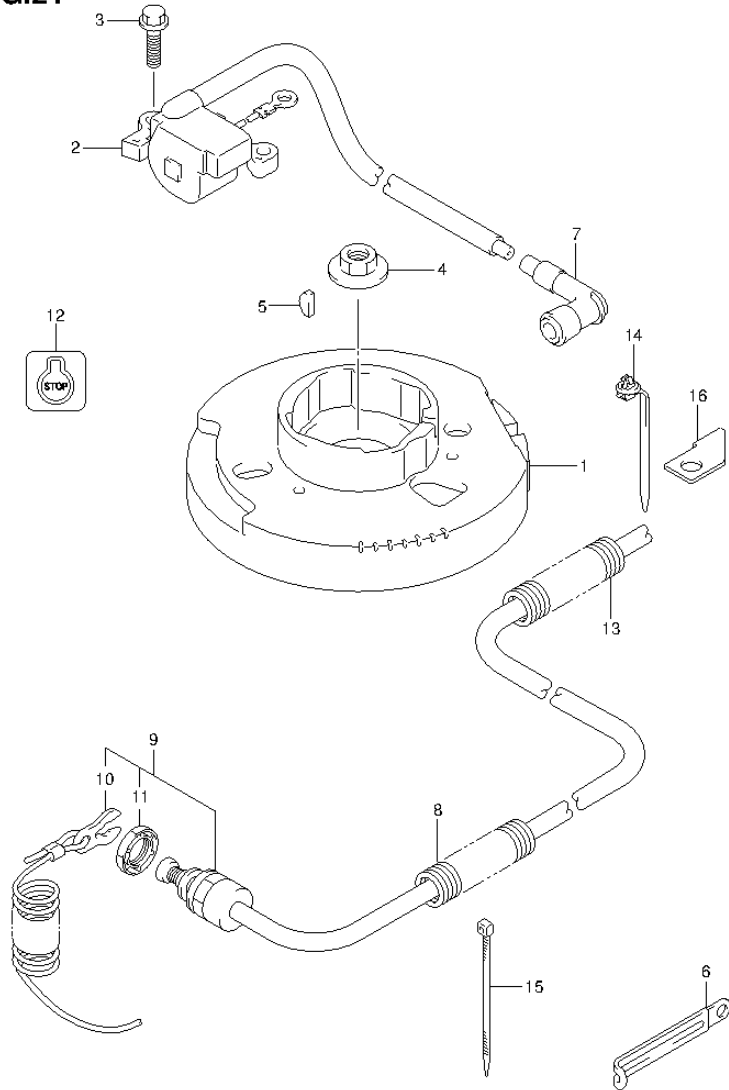

FIG.21 (1-C-12) MAGNETO

REF NO.	PART NO.	DESCRIPTION	Q'TY	REMARKS
1	32102-91J20-000	FLYWHEEL	1	
2	33410-91J40-000	UNIT, IGNITER	1	
3	01550-06207-000	BOLT	2	
4	09159-12059-000	NUT	1	
5	08341-31039-000	KEY	1	
6	29404-93J20-000	CLAMP (L:80)	1	
7	33500-07H00-000	CAP, SPARK PLUG	1	
8	33833-91J20-000	TUBE, SW LEAD (L:150)	1	
9	37830-91J20-000	SWITCH, EMERGENCY	1	
10	37823-97J00-000	.PLATE, LOCK	1	
11	37826-97J00-000	.NUT	1	
12	37835-95D00-000	LABEL, STOP	1	
13	33833-91J10-000	TUBE, SW LEAD (L:400)	1	
14	36991-91J00-000	CLAMP, EMER SW LEAD	1	
15	09407-10404-000	CLAMP (L:100)	1	
16	36617-91J00-000	BRACKET, EMER SW LEAD	1	

FIG.22

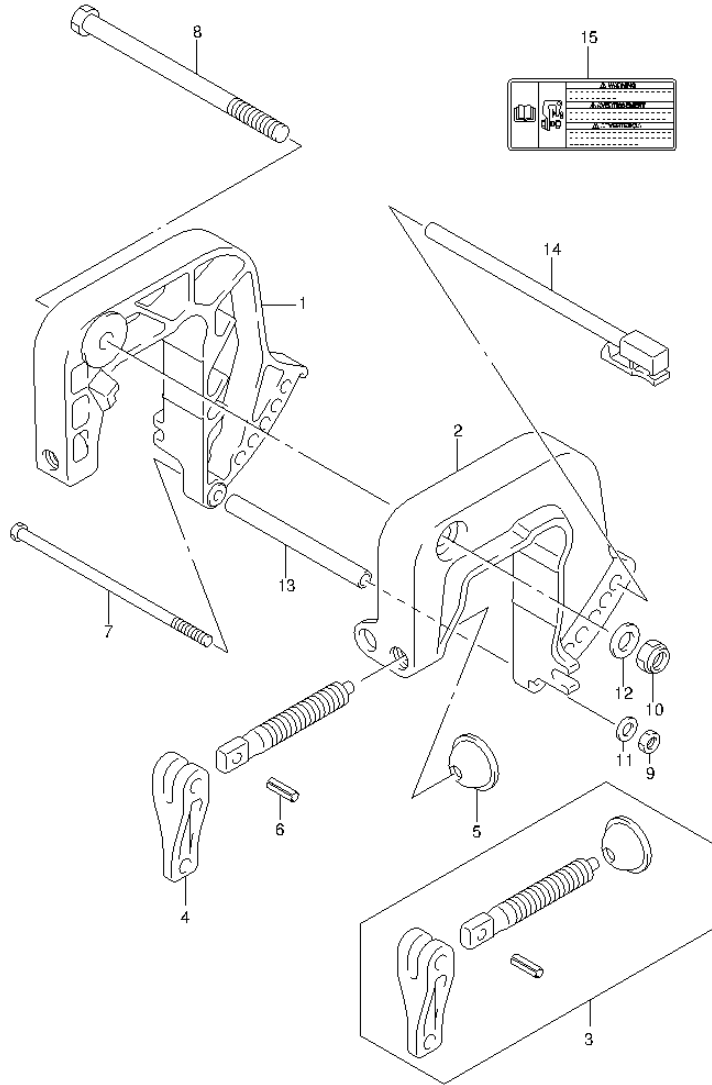

FIG.22 (1-C-13) CLAMP BRACKET

REF NO.	PART NO.	DESCRIPTION	Q'TY	REMARKS
1	41111-91J20-0EP	BRACKET, CLAMP STBD (BLACK)	1	
2	41121-91J20-0EP	BRACKET, CLAMP PORT (BLACK)	1	
3	41210-986L1-000	SCREW, ASSY CLAMP	1	OPT
4	41212-91J00-000	HANDLE, CLAMP	2	
5	41213-98100-000	PLATE, CLAMP	2	
6	09205-06007-000	SPRING PIN (6X25)	2	
7	09100-06177-000	BOLT (6X140)	1	
8	09100-10321-000	BOLT (10X150)	1	
9	29141-93J00-000	NUT	1	
10	09159-10L07-000	NUT	1	
11	09160-06082-000	WASHER (6.5X13X1.0)	1	
12	09160-10082-000	WASHER (10.5X19X2)	1	
13	09180-06357-000	SPACER (6.5X10.5X104)	1	
14	45420-92DL0-000	PIN, TILT LOCK	1	
15	69911-91J40-000	MARK, CLAMP BRACKET	1	

FIG.23

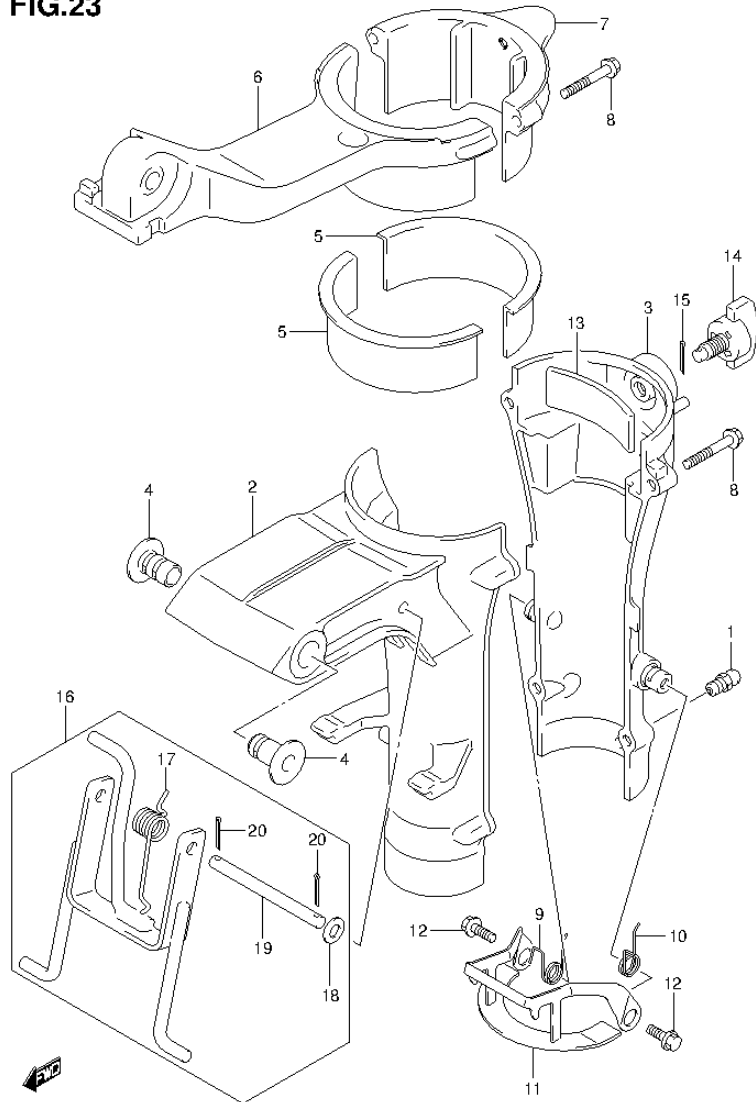

FIG.23 (1-C-14) SWIVEL BRACKET

REF NO.	PART NO.	DESCRIPTION	Q'TY	REMARKS
1	22511-99011-000	NIPPLE, GREASE	1	
2	43111-91J20-0EP	BRACKET, SWIVEL (BLACK)	1	
3	43121-91J31-0EP	COVER, SWIVEL BRACKET (BLACK)	1	
4	43211-91J00-000	BUSH, CLAMP BRKT BOLT	2	
5	43711-91J01-000	BUSH, STEERING UPPER	2	
6	43751-91J20-0EP	BRACKET, STEERING (BLACK)	1	
7	43752-91J20-0EP	COVER, STEERING BRKT (BLACK)	1	
8	09116-06099-000	BOLT (6X35)	6	
9	45211-98602-000	SPRING, REVERSE LOCK ARM STBD	1	
10	45212-98602-000	SPRING, REVERSE LOCK ARM PORT	1	
11	45230-91JL0-000	ARM, REVERSE LOCK	1	
12	09116-06094-000	BOLT (6X15)	2	
13	43411-91J10-000	ADJUSTER, STEERING	1	
14	43410-91J20-000	KNOB, STEERING ADJUSTER	1	
15	09204-01002-000	PIN	1	
16	45700-91JL0-000	ARM ASSY, SHALLOW WATER DRIVE	1	
17	45722-91J00-000	.SPRING, SHALLOW WATER DRIVE	1	
18	09160-08082-000	.WASHER (8.5X16X1.2)	1	
19	09200-08045-000	.PIN	1	
20	09204-01002-000	.PIN	2	

FIG.24

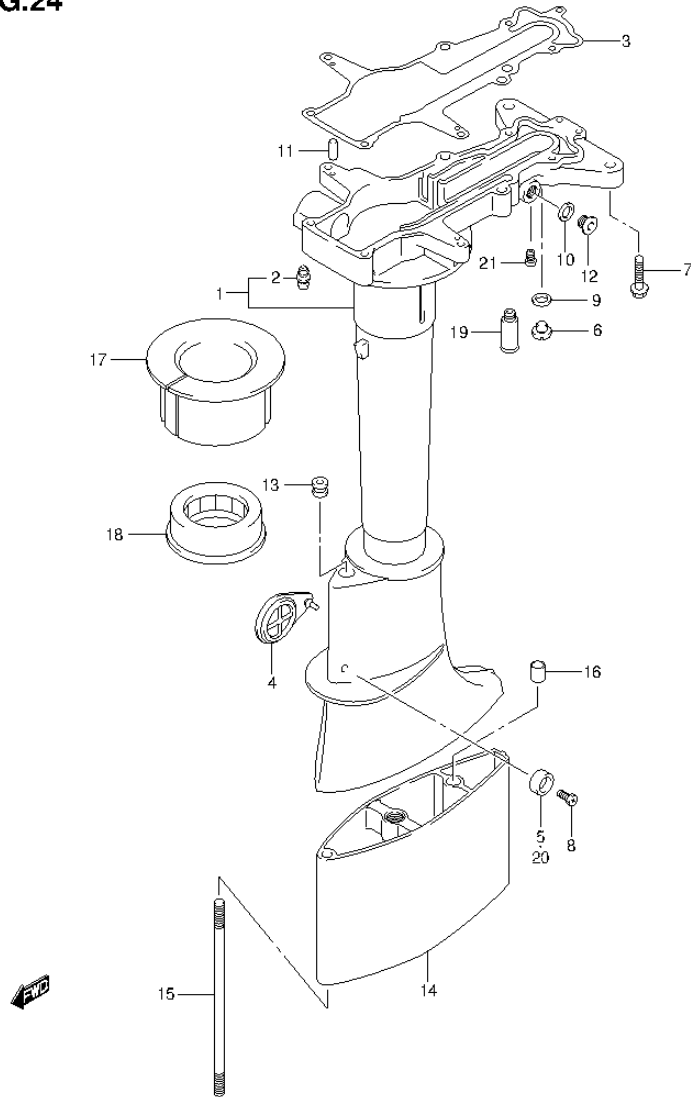

FIG.24 (1-C-15) DRIVE SHAFT HOUSING

REF NO.	PART NO.	DESCRIPTION	Q'TY	REMARKS
1	52110-91J00-0EP	HOUSING, DRIVE SHAFT (BLACK)	1	
2	22511-99011-000	.NIPPLE, GREASE	1	
3	52113-91J01-000	GASKET, DRIVE SHAFT HSG	1	
4	52115-98600-000	COVER, CLUTCH ADJUST HOLE	1	
5	55321-87J00-000	ANODE, PROTECTION	1	
6	09248-10008-000	PLUG (10X7.5)	1	
7	09116-06189-000	BOLT (6X38)	9	
8	09103-06281-000	BOLT (6X14)	1	
9	09168-10022-000	GASKET (10X17X1.5)	1	
10	09168-12017-000	GASKET (12X17X1)	1	
11	09202-06015-000	PIN	2	
12	09248-12007-000	PLUG (12X9)	1	
13	09320-04010-000	BUSH	1	
14	52131-91J20-0EP	CASE, EXTENSION (BLACK)	1	W/TRANSOM(L)
15	09108-08092-000	STUD BOLT	2	W/TRANSOM(L)
16	09206-11006-000	PIN (8.4X11X8)	1	W/TRANSOM(L)
17	54132-91J10-000	RUBBER, MOUNT UPPER	1	
18	54162-91J00-000	RUBBER, MOUNT LOWER	1	
19	55181-95200-000	ATTACHMENT, FLUSH HOSE	1	OPT
20	55321-87J10-000	ANODE (MAGNESIUM)	1	OPT
21	52117-92D00-000	TUBE, WATER INSPECTION	1	

FIG.25

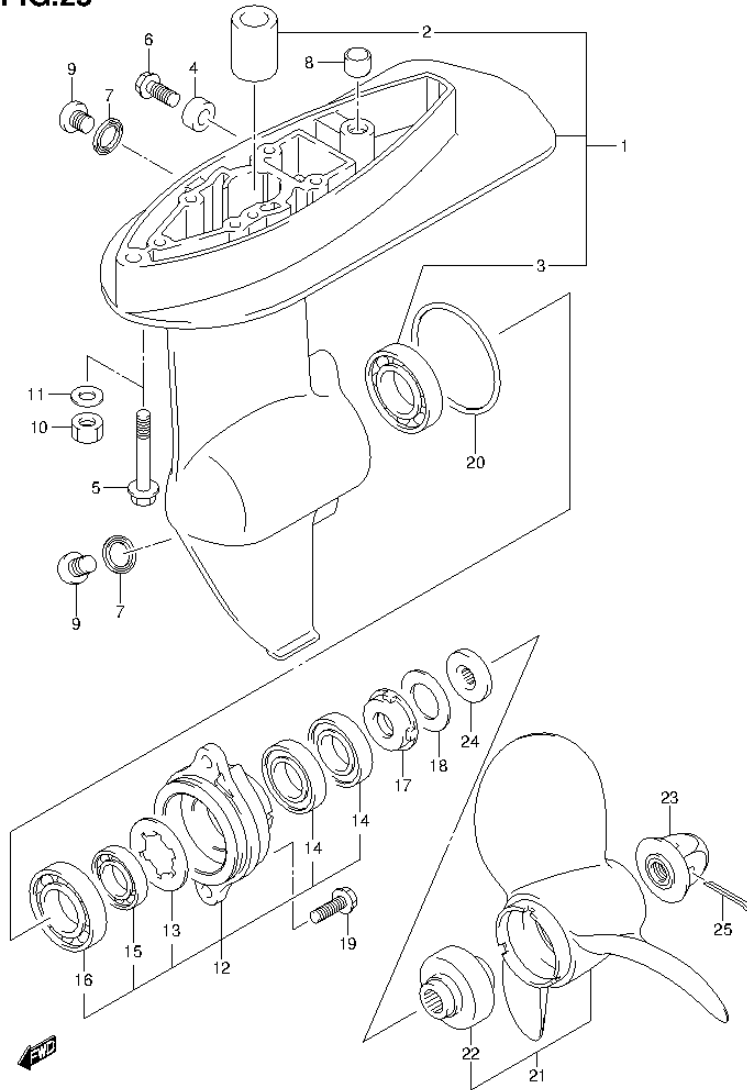

FIG.25 (1-D-2) GEAR CASE

REF NO.	PART NO.	DESCRIPTION	Q'TY	REMARKS
1	55100-91J30-0EP	CASE ASSY, GEAR (BLACK)	1	
2	59311-91J00-000	.BUSH	1	
3	09262-20106-000	.BEARING (20X42X12)	1	
4	55321-87J00-000	ANODE, PROTECTION	1	
5	09116-08156-000	BOLT (8X50)	2	W/TRANSOM(S)
6	09103-06281-000	BOLT (6X14)	1	
7	09168-10022-000	GASKET (10X17X1.5)	2	
8	09206-11006-000	PIN (8.4X11X8)	1	
9	09248-10008-000	PLUG (10X7.5)	2	
10	09140-08023-XC0	NUT	2	W/TRANSOM(L)
11	09160-08082-000	WASHER (8.5X16X1.2)	2	W/TRANSOM(L)
12	56120-91JM0-0EP	HOUSING, PROP SFT BRG (BLACK)	1	
13	09167-23001-000	.WASHER	1	
14	09282-12L05-000	.OIL SEAL	2	
15	09262-12001-000	.BEARING (12X28X8)	1	
16	09262-20106-000	.BEARING (20X42X12)	1	
17	56122-98601-000	PROTECTOR, OIL SEAL	1	
18	56123-98600-000	WASHER, PROTECTOR	1	
19	09116-06225-000	BOLT (6X16)	2	
20	09280-49002-000	O RING (D:2.6, ID:48.7)	1	
21-1	58110-91JL0-019	PROPELLER (3X7-1/2X6) (BLACK)	1	
21-2	58110-91JM0-019	PROPELLER (3X7-1/2X6-1/2) (BLACK)	1	
21-3	58110-91JN0-019	PROPELLER (3X7-1/2X7) (BLACK)	1	
22	58120-91JL0-000	.BUSH, PROPELLER	1	
23	58130-91JL0-000	NUT, PROPELLER	1	
24	57635-91JL0-000	STOPPER, PROPELLER BUSH	1	
25	09204-03003-000	PIN	1	

FIG.26

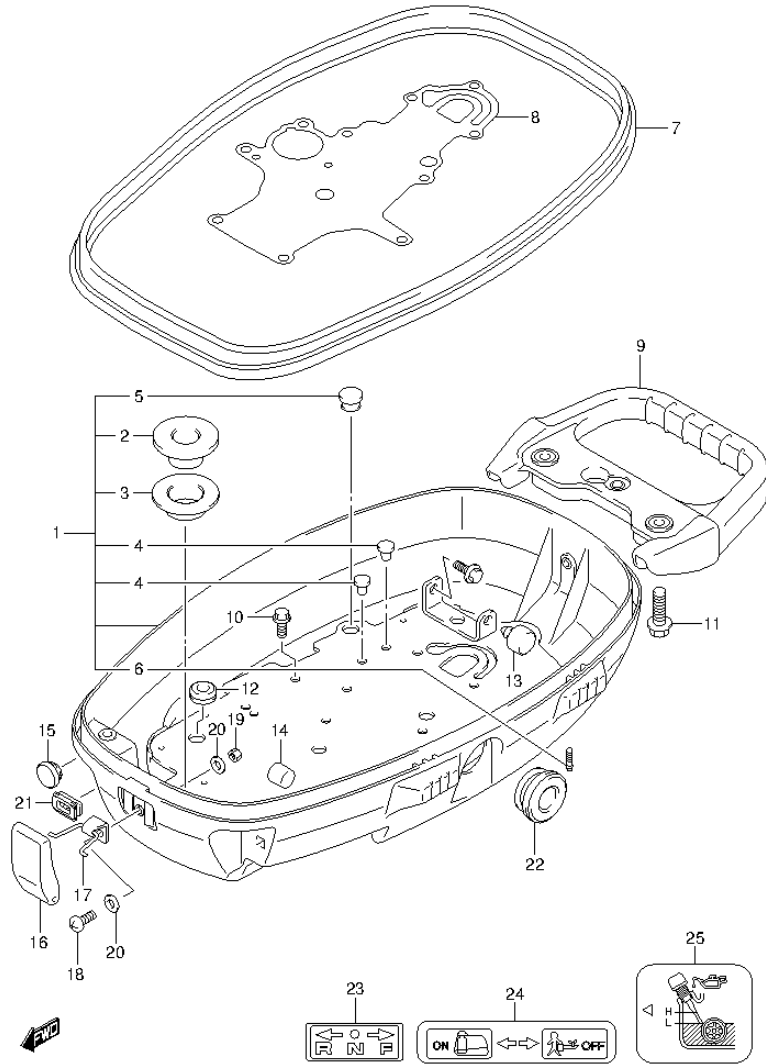
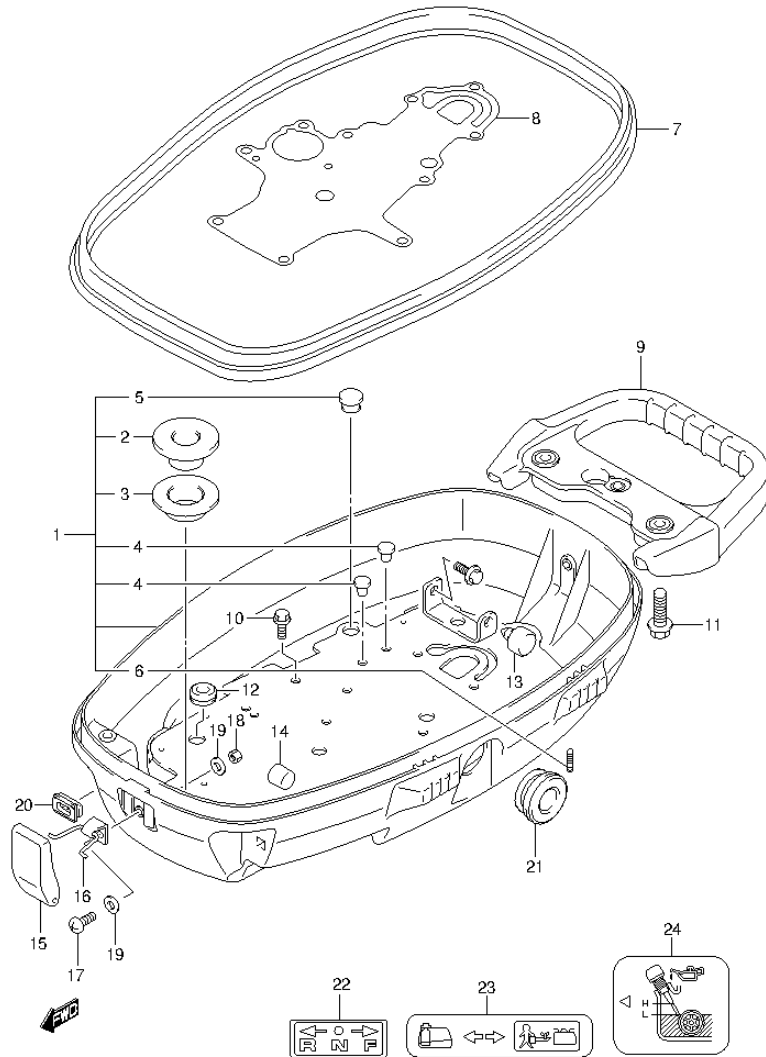

FIG.26 (1-D-3) LOWER COVER (DF4 P01)

REF NO.	PART NO.	DESCRIPTION	Q'TY	REMARKS
1	61100-91JA0-OEP	COVER ASSY, LOWER (BLACK)	1	
2	65132-91J00-000	.CUSHION	1	
3	65197-91JL0-000	.HOLDER, FUEL TANK	1	
4	09250-06005-000	.PLUG (OD:12)	2	
5	09250-12004-000	.CAP (OD:17)	1	
6	61155-94400-000	.TUBE, AIR VENT HOSE	1	
7	61112-91JL0-000	RUBBER, ENGINE LOWER COVER	1	
8	61126-91J01-000	GASKET, LOWER COVER PLATE	1	
9	61950-91J20-000	HANDLE, CARRYING	1	
10	09116-06225-000	BOLT (6X16)	2	
11	09116-08150-000	BOLT (8X27)	2	
12	09308-08011-000	GROMMET	1	
13	61151-91J11-000	CUSHION	1	
14	61151-91J20-000	CUSHION	1	
15	09250-12006-000	CAP (OD:20)	1	
16	61611-91J00-000	FASTENER, ENGINE COVER	2	
17	61640-91J10-000	LEVER, FASTENER	2	
18	09125-05132-000	SCREW (5X14)	2	
19	09140-05005-000	NUT	2	
20	09160-05029-000	WASHER (5.5X12X0.8)	4	
21	63625-96300-000	GROMMET, THROTTLE CABLE	1	
22	63624-91J00-000	GROMMET, OIL LEVEL GAUGE	1	
23	21131-96010-000	MARK, CLUTCH SHIFT	1	
24	61211-91J80-000	MARK, FUEL COCK	1	
25	61212-91J00-000	MARK, OIL LEVEL	1	

FIG.27



DF4_5_6_P01_013_027
LOWER COVER

FIG.27 (1-D-4) LOWER COVER (DF5 P01)

REF NO.	PART NO.	DESCRIPTION	Q'TY	REMARKS
1	61100-91JA0-0EP	COVER ASSY, LOWER (BLACK)	1	
2	65132-91J00-000	.CUSHION	1	
3	65197-91JL0-000	.HOLDER, FUEL TANK	1	
4	09250-06005-000	.PLUG (OD:12)	2	
5	09250-12004-000	.CAP (OD:17)	1	
6	61155-94400-000	.TUBE, AIR VENT HOSE	1	
7	61112-91JL0-000	RUBBER, ENGINE LOWER COVER	1	
8	61126-91J01-000	GASKET, LOWER COVER PLATE	1	
9	61950-91J20-000	HANDLE, CARRYING	1	
10	09116-06225-000	BOLT (6X16)	2	
11	09116-08150-000	BOLT (8X27)	2	
12	09308-08011-000	GROMMET	1	
13	61151-91J11-000	CUSHION	1	
14	61151-91J20-000	CUSHION	1	
15	61611-91J00-000	FASTENER, ENGINE COVER	2	
16	61640-91J10-000	LEVER, FASTENER	2	
17	09125-05132-000	SCREW (5X14)	2	
18	09140-05005-000	NUT	2	
19	09160-05029-000	WASHER (5.5X12X0.8)	4	
20	63625-96300-000	GROMMET, THROTTLE CABLE	1	
21	63624-91J00-000	GROMMET, OIL LEVEL GAUGE	1	
22	21131-96010-000	MARK, CLUTCH SHIFT	1	
23	61211-91J70-000	MARK, FUEL COCK	1	
24	61212-91J00-000	MARK, OIL LEVEL	1	

DF4_5_6_P01_013

FIG.28

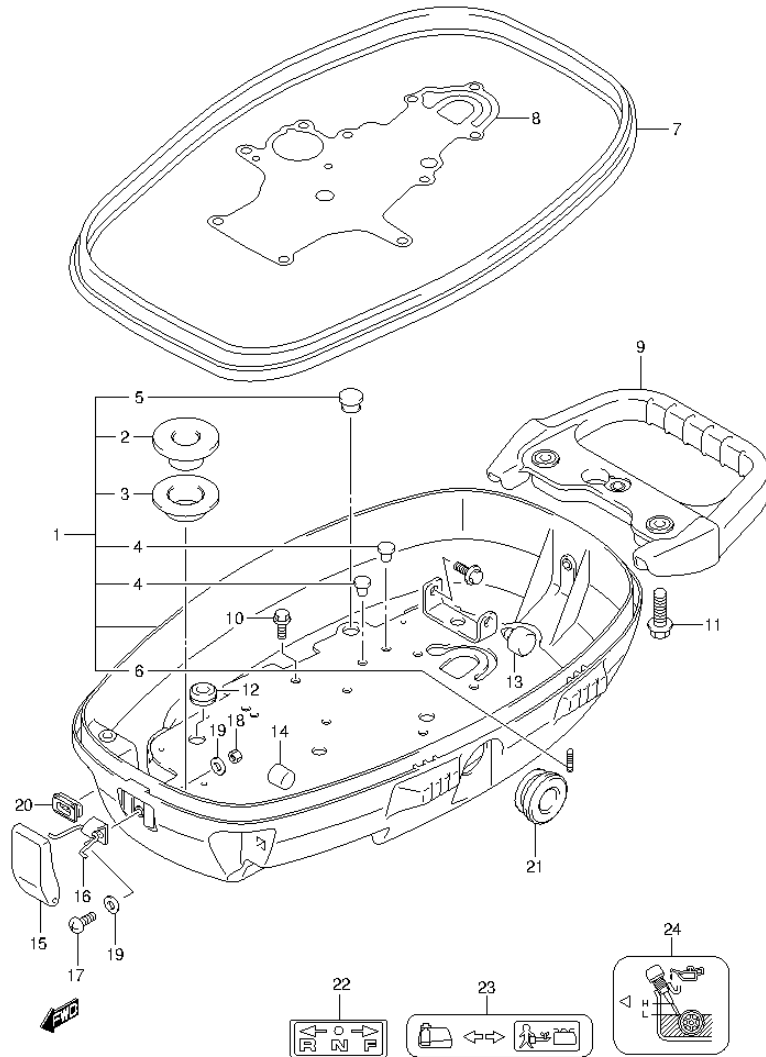

FIG.28 (1-D-5) LOWER COVER (DF6 P01)

REF NO.	PART NO.	DESCRIPTION	Q'TY	REMARKS
1	61100-91JA0-OEP	COVER ASSY, LOWER (BLACK)	1	
2	65132-91J00-000	.CUSHION	1	
3	65197-91JL0-000	.HOLDER, FUEL TANK	1	
4	09250-06005-000	.PLUG (OD:12)	2	
5	09250-12004-000	.CAP (OD:17)	1	
6	61155-94400-000	.TUBE, AIR VENT HOSE	1	
7	61112-91JL0-000	RUBBER, ENGINE LOWER COVER	1	
8	61126-91J01-000	GASKET, LOWER COVER PLATE	1	
9	61950-91J20-000	HANDLE, CARRYING	1	
10	09116-06225-000	BOLT (6X16)	2	
11	09116-08150-000	BOLT (8X27)	2	
12	09308-08011-000	GROMMET	1	
13	61151-91J11-000	CUSHION	1	
14	61151-91J20-000	CUSHION	1	
15	61611-91J00-000	FASTENER, ENGINE COVER	2	
16	61640-91J10-000	LEVER, FASTENER	2	
17	09125-05132-000	SCREW (5X14)	2	
18	09140-05005-000	NUT	2	
19	09160-05029-000	WASHER (5.5X12X0.8)	4	
20	63625-96300-000	GROMMET, THROTTLE CABLE	1	
21	63624-91J00-000	GROMMET, OIL LEVEL GAUGE	1	
22	21131-96010-000	MARK, CLUTCH SHIFT	1	
23	61211-91J70-000	MARK, FUEL COCK	1	
24	61212-91J00-000	MARK, OIL LEVEL	1	

FIG.29

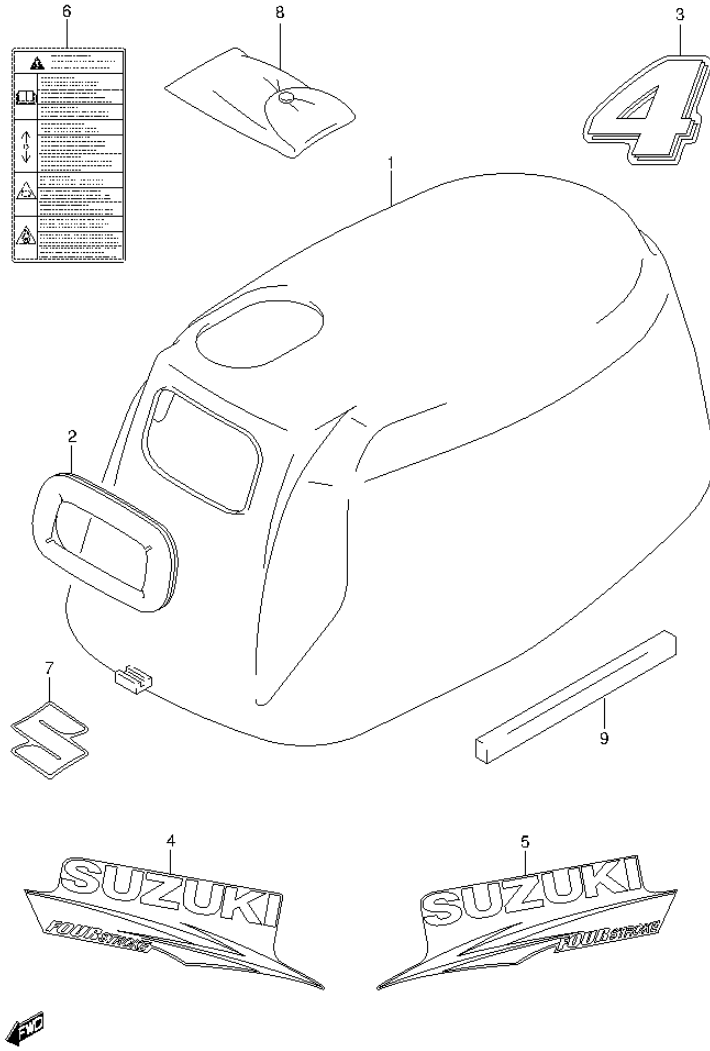

FIG.29 (1-D-6) ENGINE COVER (DF4 P01)

REF NO.	PART NO.	DESCRIPTION	Q'TY	REMARKS
1	61411-91J10-0EP	COVER, ENGINE UPPER (BLACK)	1	
2	61622-91JL0-000	SEAL, RECOIL STARTER	1	
3	61435-91J70-000	MARK, EMBLEM REAR (4)	1	
4	61443-91J40-000	STRIPE, ENGINE COVER STBD	1	
5	61453-91J40-000	STRIPE, ENGINE COVER PORT	1	
6	61458-97J30-000	LABEL, ENGINE COVER	1	
7	68111-99J00-000	EMBLEM (S)	1	
8	09800-01007-000	TOOL ASSY	1	
9	61416-91J00-000	GUARD, AIR INTAKE	1	

FIG.30

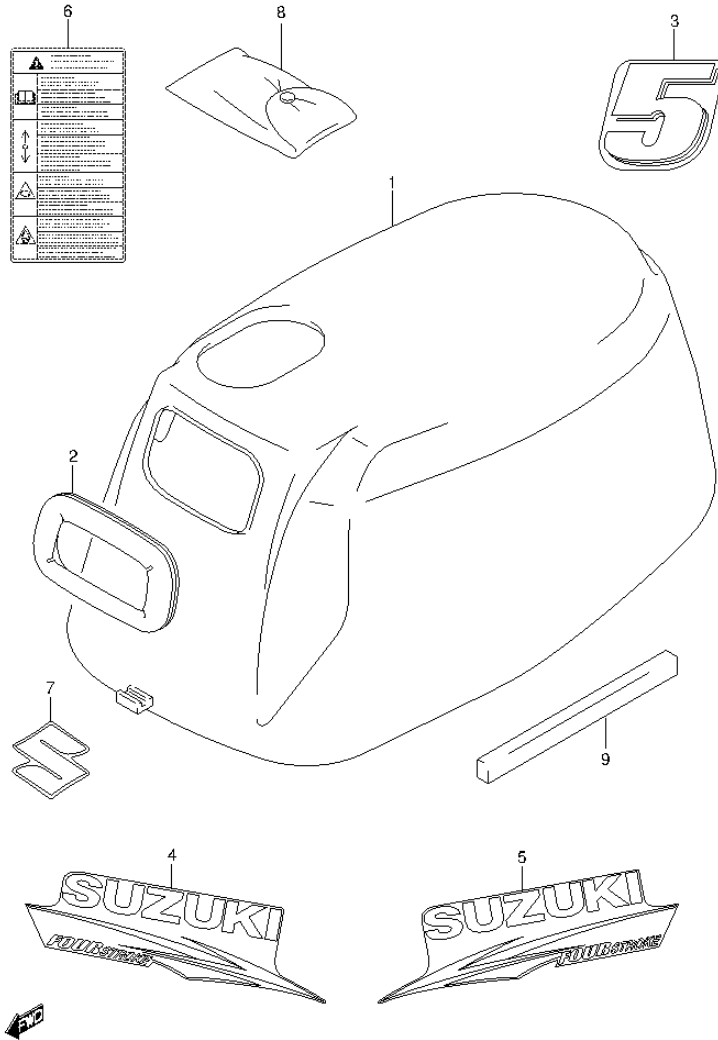

FIG.30 (1-D-7) ENGINE COVER (DF5 P01)

REF NO.	PART NO.	DESCRIPTION	Q'TY	REMARKS
1	61411-91J10-0EP	COVER, ENGINE UPPER (BLACK)	1	
2	61622-91JL0-000	SEAL, RECOIL STARTER	1	
3	61435-91J80-000	MARK, EMBLEM REAR (5)	1	
4	61443-91J40-000	STRIPE, ENGINE COVER STBD	1	
5	61453-91J40-000	STRIPE, ENGINE COVER PORT	1	
6	61458-97J30-000	LABEL, ENGINE COVER	1	
7	68111-99J00-000	EMBLEM (S)	1	
8	09800-01007-000	TOOL ASSY	1	
9	61416-91J00-000	GUARD, AIR INTAKE	1	

FIG.31

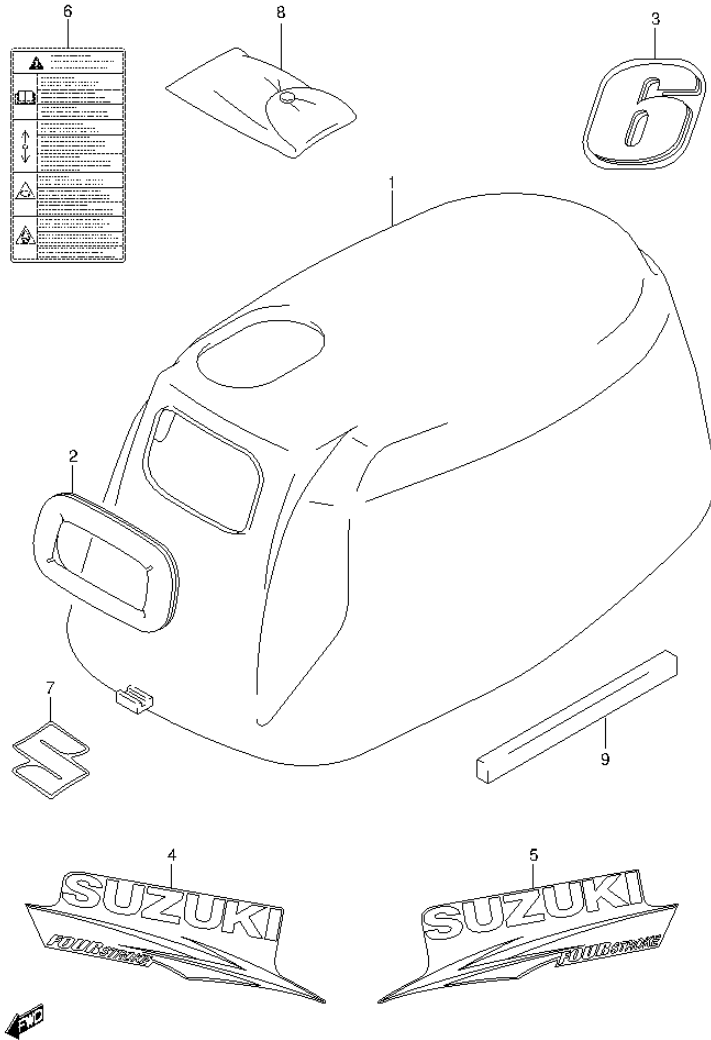

FIG.31 (1-D-8) ENGINE COVER (DF6 P01)

REF NO.	PART NO.	DESCRIPTION	Q'TY	REMARKS
1	61411-91J10-0EP	COVER, ENGINE UPPER (BLACK)	1	
2	61622-91JL0-000	SEAL, RECOIL STARTER	1	
3	61435-91J90-000	MARK, EMBLEM REAR (6)	1	
4	61443-91J40-000	STRIPE, ENGINE COVER STBD	1	
5	61453-91J40-000	STRIPE, ENGINE COVER PORT	1	
6	61458-97J30-000	LABEL, ENGINE COVER	1	
7	68111-99J00-000	EMBLEM (S)	1	
8	09800-01007-000	TOOL ASSY	1	
9	61416-91J00-000	GUARD, AIR INTAKE	1	

FIG.32

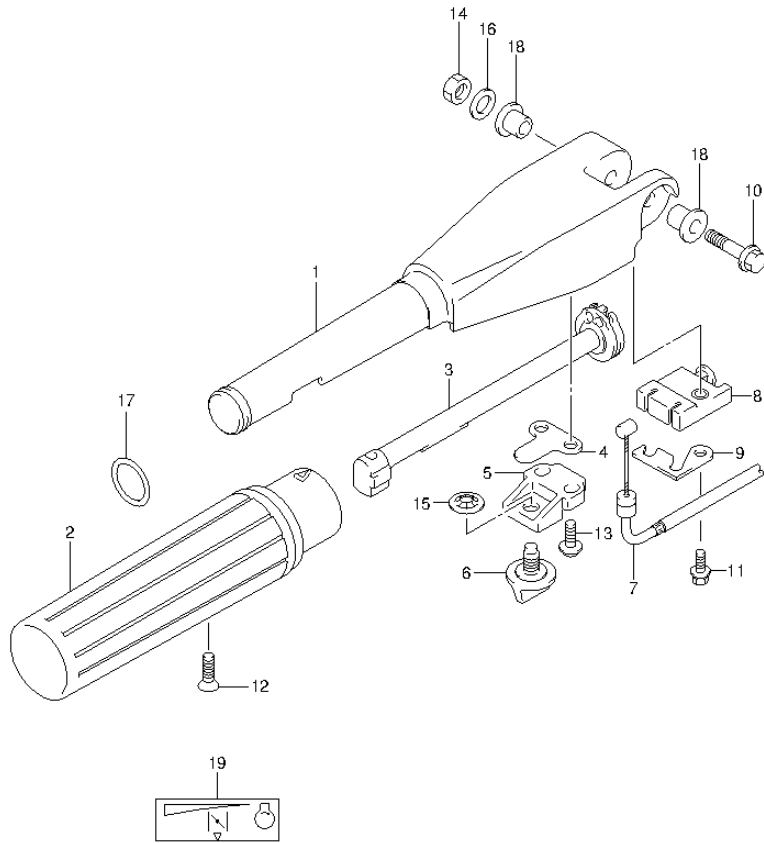

FIG.32 (1-D-9) TILLER HANDLE

REF NO.	PART NO.	DESCRIPTION	Q'TY	REMARKS
1	63111-91J21-0EP	HANDLE, TILLER (BLACK)	1	
2	63210-93E30-000	GRIP	1	
3	63221-91J10-000	ROD, HANDLE	1	
4	63225-98601-000	PLATE, HANDLE	1	
5	63241-98601-000	SUPPORT, HANDLE ROD	1	
6	63244-986A0-000	KNOB, THROTTLE ADJUST	1	
7	63610-91J20-000	CABLE, THROTTLE	2	
8	63620-91J10-000	STOPPER, THROTTLE CABLE	1	
9	63628-91J10-000	PLATE, THROTTLE CABLE STOPPER	1	
10	09116-08156-000	BOLT (8X50)	1	
11	09118-06123-000	BOLT (6X25)	1	
12	09126-06015-000	SCREW (6X23)	1	
13	09136-05041-000	SCREW (5X20)	2	
14	09140-08023-XC0	NUT	1	
15	09148-06008-000	NUT	1	
16	09160-08082-000	WASHER (8.5X16X1.2)	1	
17	09280-20004-000	O RING (D:2.4,ID:19.8)	1	
18	09306-08016-000	BUSH	2	
19	69714-91J20-000	MARK, ENGINE START	1	

FIG.33

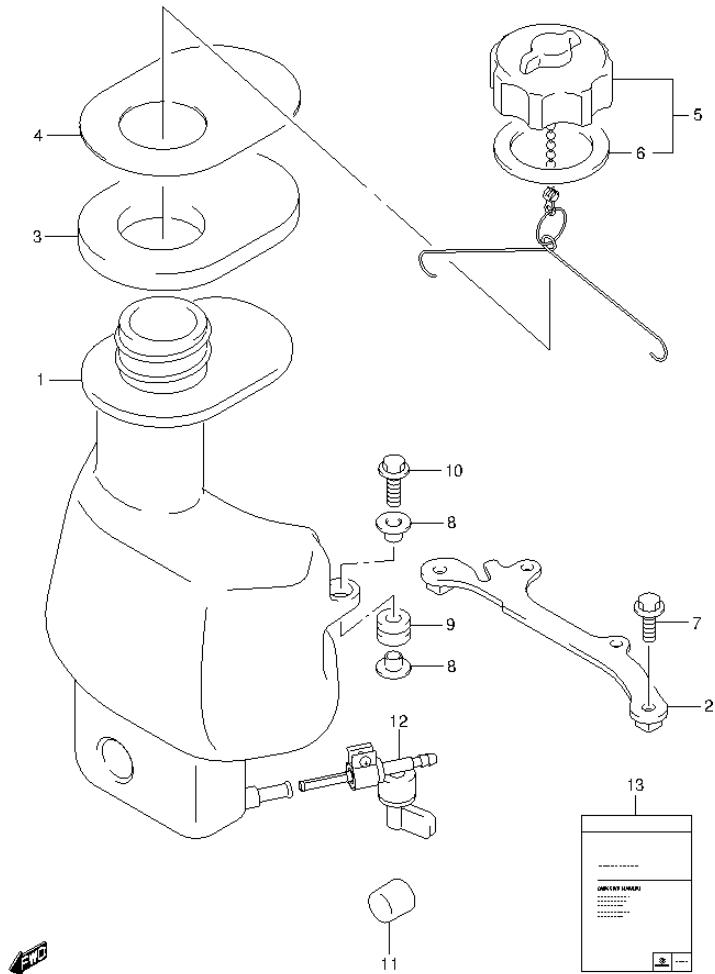

FIG.33 (1-D-10) FUEL TANK (DF4 P01)

REF NO.	PART NO.	DESCRIPTION	Q'TY	REMARKS
1	65110-91J31-000	TANK, FUEL	1	
2	65260-91J00-000	BRACKET, FUEL TANK	1	
3	65281-91J11-000	RUBBER, FUEL TANK	1	
4	65284-91JL0-000	RUBBER, FUEL TANK GROMMET	1	
5	65510-91JL1-000	CAP, FUEL TANK	1	
6	09168-32001-000	.GASKET (32X48X2.5)	1	
7	09103-06125-000	BOLT (6X16)	2	
8	09169-06088-000	WASHER	4	
9	09320-09039-000	CUSHION	2	
10	01550-06257-000	BOLT	2	
11	61151-91J20-000	CUSHION	2	
12	66100-91JL0-000	COCK ASSY, FUEL	1	
13	99011-91J30-055	MANUAL, OWNER'S	1	

FIG.34

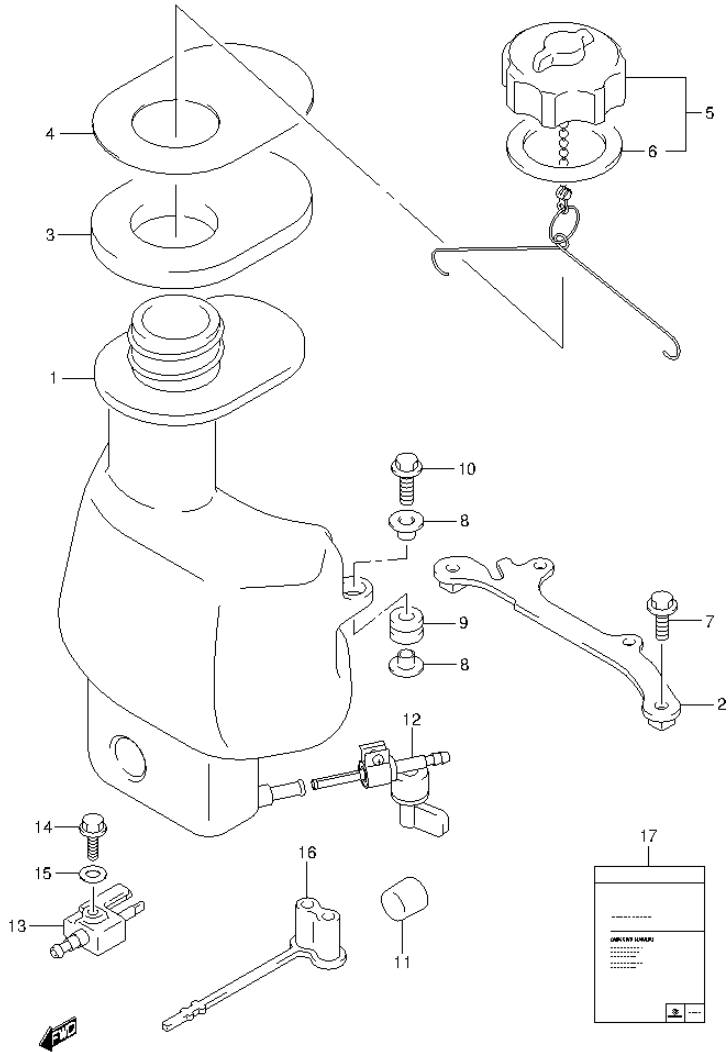

FIG.34 (1-D-11) FUEL TANK (DF5 P01)

REF NO.	PART NO.	DESCRIPTION	Q'TY	REMARKS
1	65110-91J31-000	TANK, FUEL	1	
2	65260-91J00-000	BRACKET, FUEL TANK	1	
3	65281-91J11-000	RUBBER, FUEL TANK	1	
4	65284-91JL0-000	RUBBER, FUEL TANK GROMMET	1	
5	65510-91JL1-000	CAP, FUEL TANK	1	
6	09168-32001-000	.GASKET (32X48X2.5)	1	
7	09103-06125-000	BOLT (6X16)	2	
8	09169-06088-000	WASHER	4	
9	09320-09039-000	CUSHION	2	
10	01550-06257-000	BOLT	2	
11	61151-91J20-000	CUSHION	2	
12	66100-91JL0-000	COCK ASSY, FUEL	1	
13	65720-986B0-000	PLUG, FUEL CONNECTOR	1	
14	09103-06237-000	BOLT (6X12.5)	1	
15	09160-06085-000	WASHER	1	
16	65727-91JL0-000	CAP, FUEL CONNECTOR PLUG	1	
17	99011-91J30-055	MANUAL, OWNER'S	1	

FIG.35

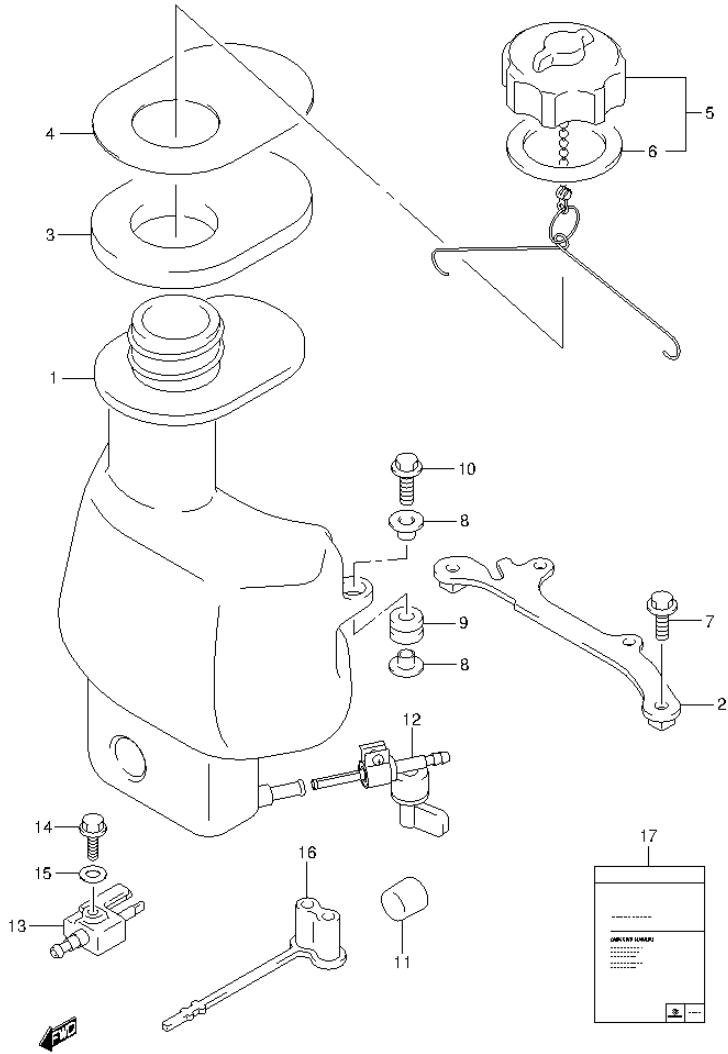

FIG.35 (1-D-12) FUEL TANK (DF6 P01)

REF NO.	PART NO.	DESCRIPTION	Q'TY	REMARKS
1	65110-91J31-000	TANK, FUEL	1	
2	65260-91J00-000	BRACKET, FUEL TANK	1	
3	65281-91J11-000	RUBBER, FUEL TANK	1	
4	65284-91JL0-000	RUBBER, FUEL TANK GROMMET	1	
5	65510-91JL1-000	CAP, FUEL TANK	1	
6	09168-32001-000	.GASKET (32X48X2.5)	1	
7	09103-06125-000	BOLT (6X16)	2	
8	09169-06088-000	WASHER	4	
9	09320-09039-000	CUSHION	2	
10	01550-06257-000	BOLT	2	
11	61151-91J20-000	CUSHION	2	
12	66100-91JL0-000	COCK ASSY, FUEL	1	
13	65720-986B0-000	PLUG, FUEL CONNECTOR	1	
14	09103-06237-000	BOLT (6X12.5)	1	
15	09160-06085-000	WASHER	1	
16	65727-91JL0-000	CAP, FUEL CONNECTOR PLUG	1	
17	99011-91J30-055	MANUAL, OWNER'S	1	

FIG.36

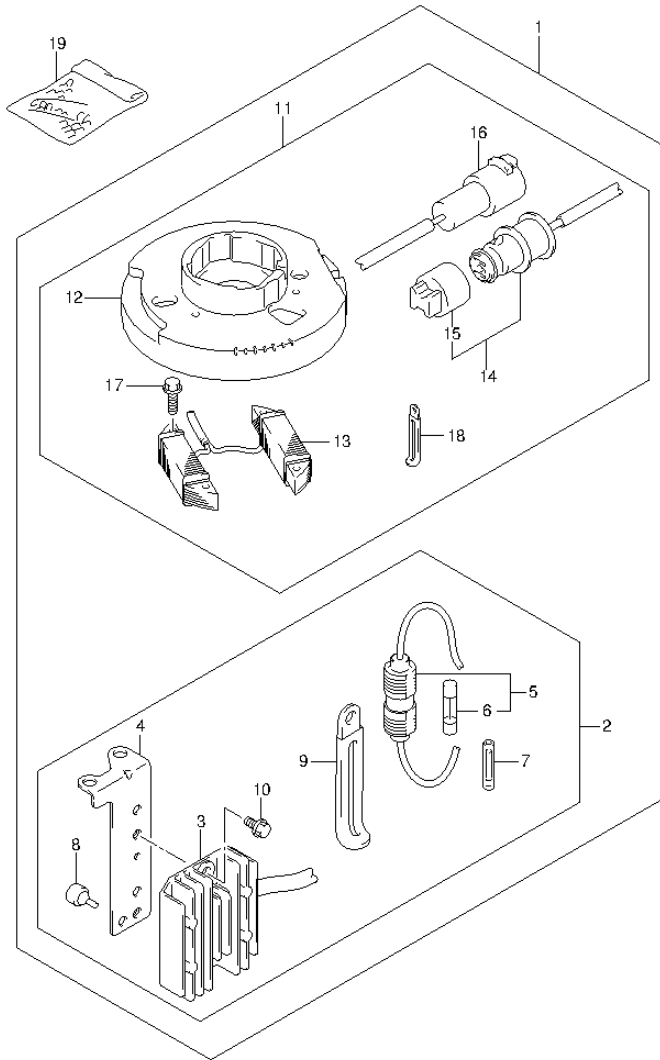

FIG.36 (1-D-13) OPT : ELECTRICAL

REF NO.	PART NO.	DESCRIPTION	Q'TY	REMARKS
1	32000-91J10-000	KIT, BATTERY CHARGING	1	
2	32801-91J00-000	..RECTIFIER SET	1	
3	32800-94620-000	..RECTIFIER / REGULATOR ASSY	1	
4	32890-91J00-000	..BRACKET, RECTIFIER	1	
5	36740-95253-000	..CASE ASSY, FUSE	1	
6	09481-20001-000	...FUSE (20A)	1	
7	37132-93700-000	..TERMINAL, LEAD WIRE	2	
8	09321-05019-000	..CUSHION	1	
9	09404-06435-000	..CLAMP (L:135)	1	
10	01550-06127-000	..BOLT	2	
11	39600-91J10-000	..COIL SET, RECEPTACLE	1	
12	32102-91J30-000	..FLYWHEEL, MAGNETO	1	
13	32120-91J10-000	..COIL, LIGHTING	2	
14	39601-95D00-000	..RECEPTACLE, LIGHTING	1	
15	36634-93910-000	...CAP, LIGHTING RECEPTACLE	1	
16	39602-93900-000	..PLUG, LIGHTING	1	
17	01550-06207-000	..BOLT	4	
18	09404-06429-000	..CLAMP (L:45)	1	
19	36990-87D00-000	TERMINAL	1	

FIG.37

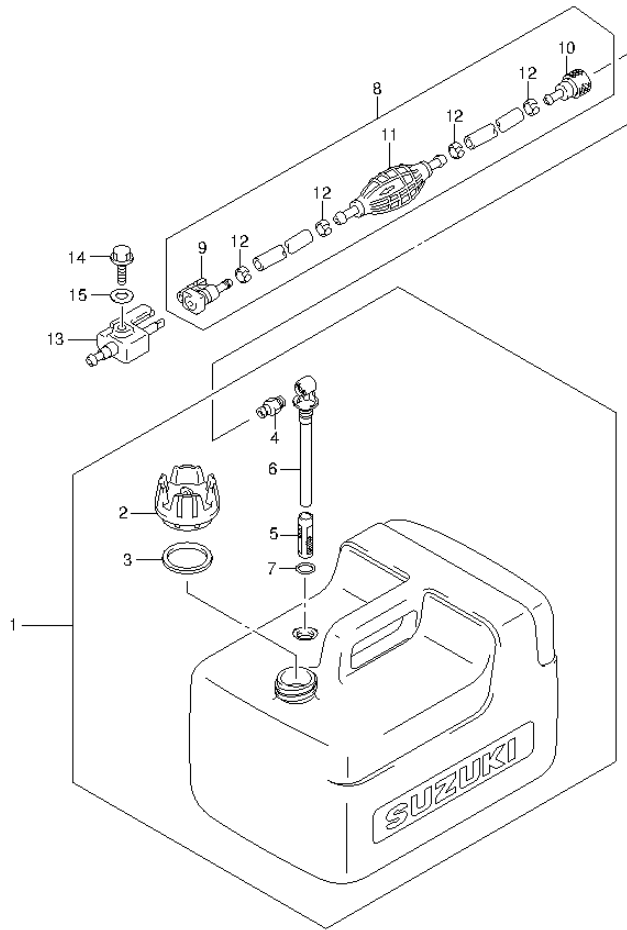

FIG.37 (1-D-14) OPT : FUEL TANK (RESIN) (DF4 P01)

REF NO.	PART NO.	DESCRIPTION	Q'TY	REMARKS
1	65000-99100-000	TANK ASSY, FUEL (12L)	1	
2	65520-99100-000	.CAP, FUEL TANK	1	
3	65561-95D00-000	.GASKET	1	
4	65740-99100-000	.PLUG, FUEL CONNECTOR	1	
5	65831-95D00-000	.FILTER OUTLET	1	
6	65890-99100-000	.OUTLET ASSY	1	
7	65892-95D00-000	.O RING	1	
8	65700-94JD0-000	HOSE, FUEL	1	
9	65750-87J11-000	.SOCKET, FUEL HOSE	1	
10	65750-98505-000	.SOCKET, FUEL HOSE	1	
11	65770-99J00-000	.PUMP, SQUEEZE	1	
12	65781-98500-000	.CLIP, FUEL HOSE	4	
13	65720-986B0-000	PLUG, FUEL CONNECTOR	1	
14	09103-06237-000	BOLT (6X12.5)	1	
15	09160-06085-000	WASHER	1	

FIG.38

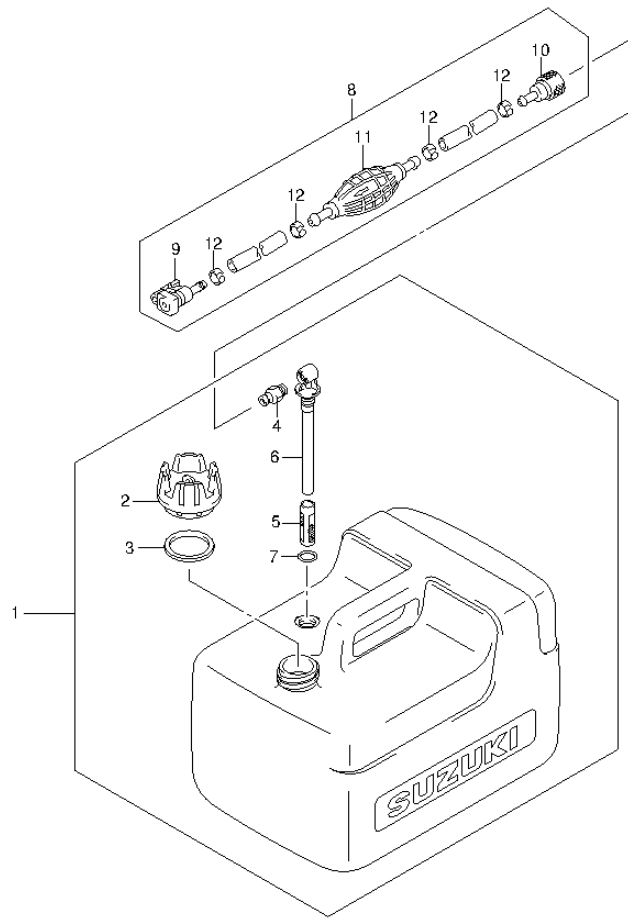

FIG.38 (1-D-15) OPT : FUEL TANK (RESIN) (DF5 P01)

REF NO.	PART NO.	DESCRIPTION	Q'TY	REMARKS
1	65000-99100-000	TANK ASSY, FUEL (12L)	1	
2	65520-99100-000	.CAP, FUEL TANK	1	
3	65561-95D00-000	.GASKET	1	
4	65740-99100-000	.PLUG, FUEL CONNECTOR	1	
5	65831-95D00-000	.FILTER OUTLET	1	
6	65890-99100-000	.OUTLET ASSY	1	
7	65892-95D00-000	.O RING	1	
8	65700-94JD0-000	HOSE, FUEL	1	
9	65750-87J11-000	.SOCKET, FUEL HOSE	1	
10	65750-98505-000	.SOCKET, FUEL HOSE	1	
11	65770-99J00-000	.PUMP, SQUEEZE	1	
12	65781-98500-000	.CLIP, FUEL HOSE	4	

FIG.39

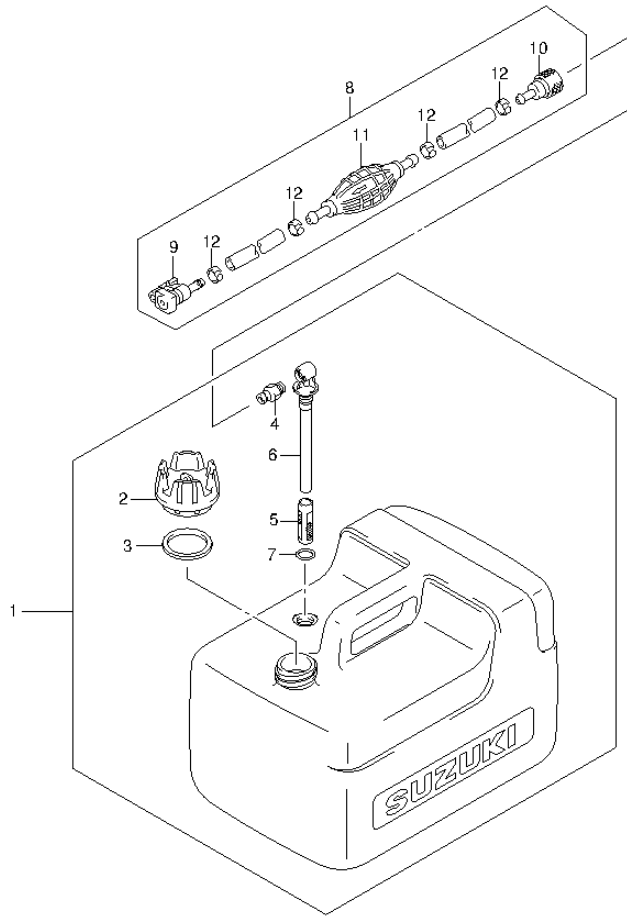

FIG.39 (1-E-2) OPT : FUEL TANK (RESIN) (DF6 P01)

REF NO.	PART NO.	DESCRIPTION	Q'TY	REMARKS
1	65000-99100-000	TANK ASSY, FUEL (12L)	1	
2	65520-99100-000	.CAP, FUEL TANK	1	
3	65561-95D00-000	.GASKET	1	
4	65740-99100-000	.PLUG, FUEL CONNECTOR	1	
5	65831-95D00-000	.FILTER OUTLET	1	
6	65890-99100-000	.OUTLET ASSY	1	
7	65892-95D00-000	.O RING	1	
8	65700-94JD0-000	HOSE, FUEL	1	
9	65750-87J11-000	.SOCKET, FUEL HOSE	1	
10	65750-98505-000	.SOCKET, FUEL HOSE	1	
11	65770-99J00-000	.PUMP, SQUEEZE	1	
12	65781-98500-000	.CLIP, FUEL HOSE	4	

FIG.40

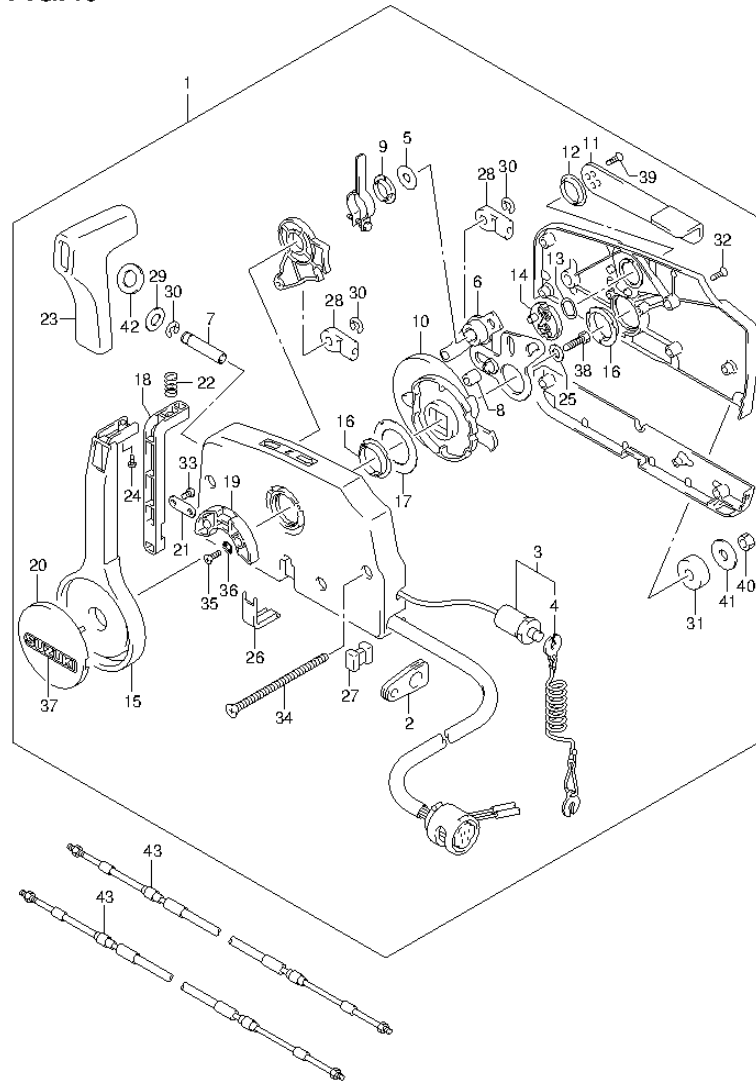
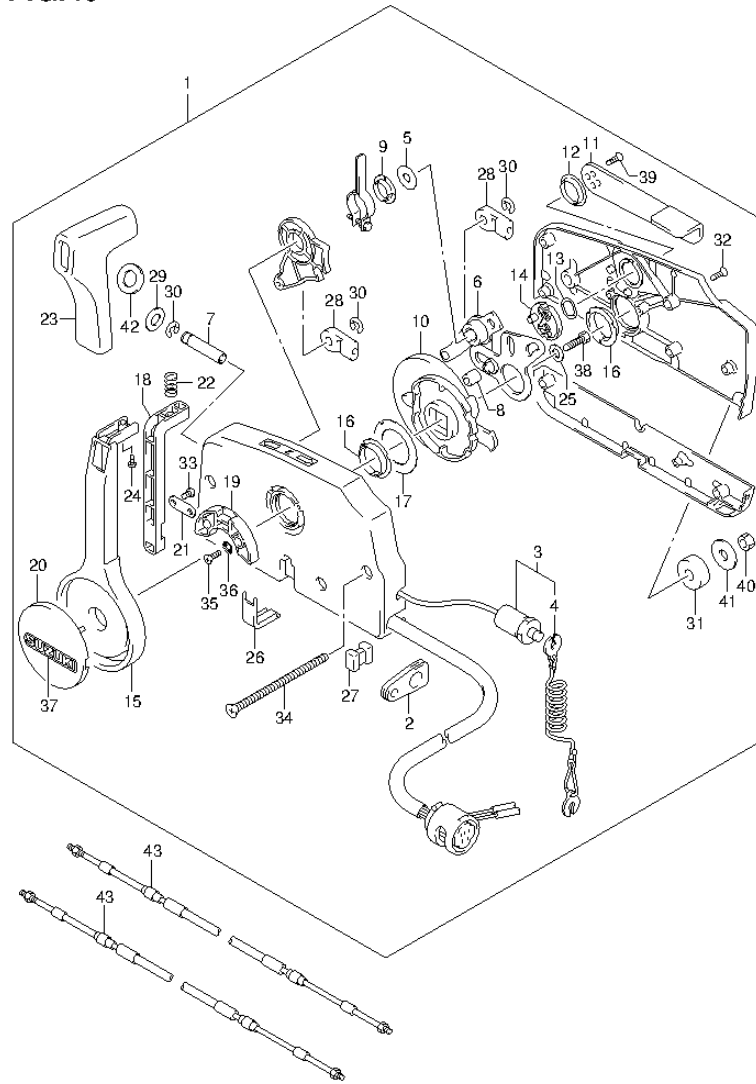

FIG.40 (1-E-3) OPT:REMOTE CONTROL

REF NO.	PART NO.	DESCRIPTION	Q'TY	REMARKS
1	67200-91J04-000	REMOTE CONTROL ASSY	1	
2	36628-92E00-000	.GROMMET, WIRE HARNESS	1	
3	37830-95D02-000	.SWITCH ASSY, EMERGENCY & STOP	1	
4	37823-92E01-000	.PLATE, LOCK	1	
5	67212-95600-000	.WASHER	1	
6	67220-95630-000	.PLATE ASSY	1	
7	67223-99E10-000	.KNOB, BRAKE ADJUST	1	
8	67229-95600-000	.ROLLER	1	
9	67232-95600-000	.BUSH	1	
10	67238-87D00-000	.GEAR, DRIVE	1	
11	67241-99E10-000	.LEVER, FREE THROTTLE	1	
12	67243-95600-000	.BUSH	1	
13	67244-95600-000	.WAVE WASHER	1	
14	67245-95600-000	.DRUM, FREE THROTTLE	1	
15	67251-99E10-000	.LEVER, HANDLE	1	
16	67252-95600-000	.BUSH	2	
17	67253-95600-000	.WASHER	1	
18	67255-99E00-000	.ARM, LOCK	1	
19	67256-95600-000	.HOLDER, NEUTRAL LOCK	1	
20	67257-99E00-000	.CAP, LEVER	1	
21	67258-99E00-000	.BRACKET	1	
22	67259-87D00-000	.SPRING, NEUTRAL ARM	1	
23	67261-99E00-000	.GRIP	1	
24	67296-94310-000	.SCREW	1	
25	67264-95600-000	.WASHER	1	
26	67267-93J00-000	.COVER, WIRE	1	
27	67273-95600-000	.SPACER	1	
28	67275-95600-000	.END, CABLE	2	
29	67288-92E00-000	.WASHER, BRAKE ADJ KNOB	1	
30	67292-94300-000	.E RING	3	
31	67294-95600-000	.SPACER	3	
32	67296-90J00-000	.SCREW, REAR COVER	5	
33	67296-94300-000	.SCREW	2	
34	67296-95600-000	.SCREW	3	

FIG.40

FIG.40 (1-E-4) OPT:REMOTE CONTROL



REF NO.	PART NO.	DESCRIPTION	Q'TY	REMARKS
35	67296-95610-000	.SCREW	2	
36	67297-95600-000	.WASHER	2	
37	68165-16B00-13L	.EMBLEM, SUZUKI (SILVER)	1	
38	09100-08232-000	.BOLT (8X30)	1	
39	09126-05003-000	.SCREW (5X12)	2	
40	09140-06020-000	.NUT	3	
41	09160-06104-000	.WASHER (6.5X24X2)	3	
42	37859-90J00-000	.SPACER	1	
43-1	67320-93J00-000	CABLE ASSY, REMOCON 8F (2.4M)	2	
43-2	67320-93J10-000	CABLE ASSY, REMOCON 10F (3.1M)	2	
43-3	67320-93J20-000	CABLE ASSY, REMOCON 12F (3.7M)	2	
43-4	67320-93J30-000	CABLE ASSY, REMOCON 14F (4.3M)	2	
43-5	67320-93J40-000	CABLE ASSY, REMOCON 16F (4.9M)	2	

FIG.41

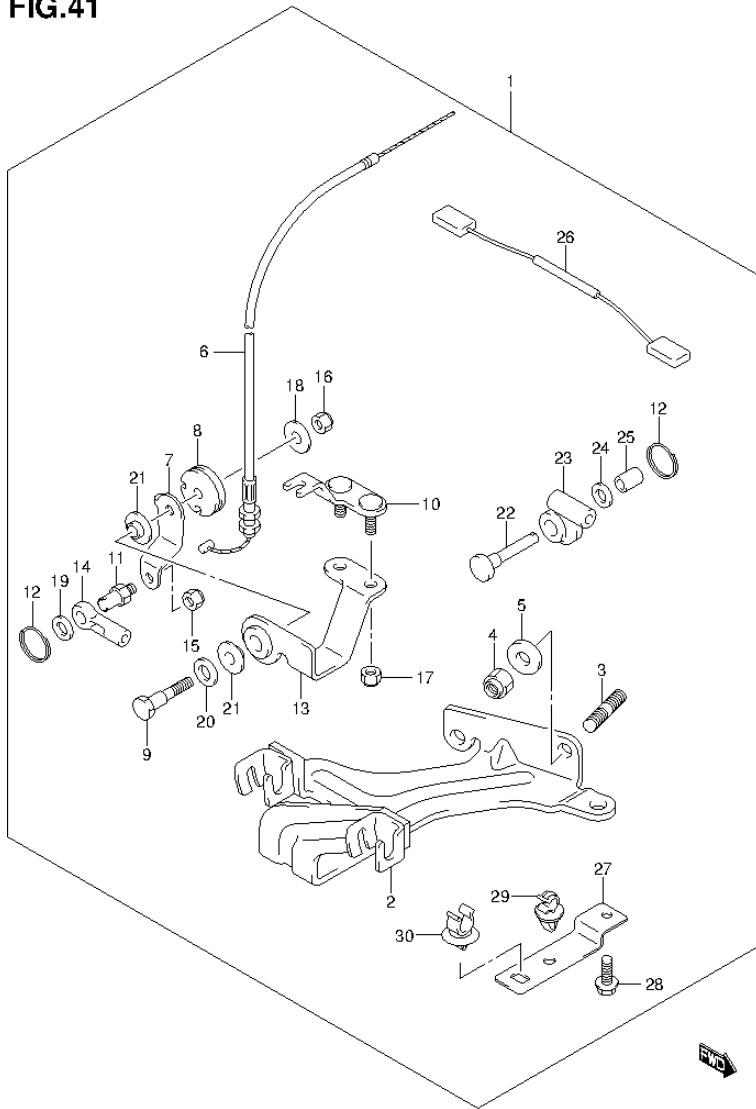

FIG.41 (1-E-5) OPT:REMOCON PARTS SET

REF NO.	PART NO.	DESCRIPTION	Q'TY	REMARKS
1	67130-91J01-000	PARTS SET, REMOCON	1	
2	67110-91J00-000	ATTACHMENT, REMOCON	1	
3	09108-08130-000	.STUD BOLT	2	
4	09159-08059-000	.NUT	2	
5	29162-93J10-000	.WASHER, REMOCON ATTACHMENT	2	
6	63610-91J11-000	.CABLE, THROTTLE	1	
7	67412-91J00-000	.LEVER, REMOCON THROTTLE	1	
8	67415-91J00-000	.DRUM, REMOCON THROTTLE	1	
9	67416-91J00-000	.BOLT, REMOCON THROTTLE LEVER	1	
10	67430-91J00-000	.GUIDE, THROTTLE CABLE	1	
11	67447-91J10-000	.BOLT, THROTTLE CABLE	1	
12	67448-91J00-000	.STOPPER, REMOCON CABLE	2	
13	67460-91J00-000	.BRACKET, REMOCON THROTTLE	1	
14	67466-95200-000	.CONNECTOR, REMOCON CABLE	1	
15	29141-93J00-000	.NUT, THROTTLE CABLE	1	
16	09159-06079-000	.NUT	1	
17	09159-06079-000	.NUT	2	
18	09160-06104-000	.WASHER (6.5X24X2)	1	
19	09160-08091-000	.WASHER (8.5X14X1.0)	1	
20	09164-08017-000	.WASHER	1	
21	09306-08002-000	.BUSH	2	
22	67447-91J00-000	.PIN, CLUTCH CABLE	1	
23	67467-93E01-000	.CONNECTOR, REMOCON CABLE	1	
24	09160-06082-000	.WASHER (6.5X13X1.0)	1	
25	09180-06097-000	.SPACER (6.1X9X12.3)	1	
26	36831-91J00-000	.LEAD, STOP SW	1	
27	65791-91J00-000	.BRACKET, HOSE & CABLE CLAMP	1	
28	29103-93J00-000	.BOLT, HOSE & CABLE CLAMP	1	
29	09403-07325-000	.CLAMP	1	
30	09403-12314-000	.CLAMP	1	

PART NO.	FIG.NO.-REF.NO.	PART NO.	FIG.NO.-REF.NO.	PART NO.	FIG.NO.-REF.NO.
54132-91J10-000	24-17		27-13	61950-91J20-000	26-9
54162-91J00-000	24-18		28-13		27-9
55100-91J30-0EP	25-1	61151-91J20-000	26-14		28-9
55181-95200-000	24-19		27-14	63111-91J21-0EP	32-1
55321-87J00-000	24-5		28-14	63210-93E30-000	32-2
	25-4		33-11	63221-91J10-000	32-3
55321-87J10-000	24-20		34-11	63225-98601-000	32-4
56120-91JM0-0EP	25-12		35-11	63241-98601-000	32-5
56122-98601-000	25-17	61155-94400-000	26-6	63244-986A0-000	32-6
56123-98600-000	25-18		27-6	63610-91J11-000	41-6
56130-91J20-000	15-16		28-6	63610-91J20-000	32-7
56132-91J00-000	15-18	61211-91J70-000	27-23	63620-91J10-000	32-8
57111-91J20-000	20-1-1		28-23	63624-91J00-000	26-22
57111-91J30-000	20-1-2	61211-91J80-000	26-24		27-21
57130-91JL0-000	20-3	61212-91J00-000	26-25		28-21
57311-91J00-000	20-5		27-24	63625-96300-000	26-21
57510-91J00-000	20-8		28-24		27-20
57521-91J00-000	20-9	61411-91J10-0EP	29-1		28-20
57611-91J10-000	20-14		30-1	63628-91J10-000	32-9
57621-986L0-000	20-15		31-1	65000-99100-000	37-1
57631-98601-000	20-19	61416-91J00-000	29-9		38-1
57632-98500-000	20-20		30-9		39-1
57635-91JL0-000	25-24		31-9	65110-91J31-000	33-1
58110-91JL0-019	25-21-1	61435-91J70-000	29-3		34-1
58110-91JM0-019	25-21-2	61435-91J80-000	30-3		35-1
58110-91JN0-019	25-21-3	61435-91J90-000	31-3	65132-91J00-000	26-2
58120-91JL0-000	25-22	61443-91J40-000	29-4		27-2
58130-91JL0-000	25-23		30-4		28-2
59311-91J00-000	25-2		31-4	65197-91JL0-000	26-3
59412-91J00-000	12-11	61453-91J40-000	29-5		27-3
	13-14		30-5		28-3
	14-14		31-5	65260-91J00-000	33-2
		61458-97J30-000	29-6		34-2
			30-6		35-2
			31-6	65281-91J11-000	33-3
		61472-91J30-000	16-14		34-3
		61493-91J00-000	16-15		35-3
		61494-91J00-000	16-16	65284-91JL0-000	33-4
		61611-91J00-000	26-16		34-4
			27-15		35-4
61100-91JA0-0EP	26-1		28-15	65510-91JL1-000	33-5
	27-1	61622-91JL0-000	29-2		34-5
	28-1		30-2		35-5
61112-91JL0-000	26-7		31-2	65520-99100-000	37-2
	27-7	61640-91J10-000	26-17		38-2
	28-7		27-16		39-2
61126-91J01-000	26-8		28-16	65561-95D00-000	37-3
	27-8	61827-91J00-000	1-7		38-3
	28-8		2-7		39-3
61151-91J11-000	26-13		3-7	65700-94JD0-000	37-8

60000

PART NO.	FIG.NO.-REF.NO.	PART NO.	FIG.NO.-REF.NO.	PART NO.	FIG.NO.-REF.NO.
					38-8
					39-8
65720-986B0-000	34-13			67253-95600-000	40-17
	35-13			67255-99E00-000	40-18
	37-13			67256-95600-000	40-19
	34-16			67257-99E00-000	40-20
65727-91JL0-000	35-16			67258-99E00-000	40-21
	37-4			67259-87D00-000	40-22
65740-99100-000	38-4			67261-99E00-000	40-23
	39-4			67264-95600-000	40-25
	37-9			67267-93J00-000	40-26
65750-87J11-000	38-9			67273-95600-000	40-27
	39-9			67275-95600-000	40-28
	39-9			67288-92E00-000	40-29
65750-98505-000	37-10			67292-94300-000	40-30
	38-10			67294-95600-000	40-31
	39-10			67296-90J00-000	40-32
	37-11			67296-94300-000	40-33
65770-99J00-000	38-11			67296-94310-000	40-34
	39-11			67296-95600-000	40-34
	37-12			67296-95610-000	40-35
65781-98500-000	38-12			67297-95600-000	40-36
	39-12			67320-93J00-000	40-43-1
	39-12			67320-93J10-000	40-43-2
65791-91J00-000	41-27			67320-93J20-000	40-43-3
65831-95D00-000	37-5			67320-93J30-000	40-43-4
	38-5			67320-93J40-000	40-43-5
	39-5			67412-91J00-000	41-7
65890-99100-000	37-6			67415-91J00-000	41-8
	38-6			67416-91J00-000	41-9
	39-6			67430-91J00-000	41-10
65892-95D00-000	37-7			67447-91J00-000	41-22
	38-7			67447-91J10-000	41-11
	39-7			67448-91J00-000	41-12
66100-91JL0-000	33-12			67460-91J00-000	41-13
	34-12			67466-95200-000	41-14
	35-12			67467-93E01-000	41-23
	41-2			68111-99J00-000	29-7
67110-91J00-000	41-1				30-7
67130-91J01-000	40-1				31-7
67200-91J04-000	40-5			68165-16B00-13L	40-37
67212-95600-000	40-6			69711-93E10-000	16-13
67220-95630-000	40-7			69714-91J20-000	32-19
67223-99E10-000	40-8			69911-91J40-000	22-15
67229-95600-000	40-9				
67232-95600-000	40-10				
67238-87D00-000	40-11				
67241-99E10-000	40-12				
67243-95600-000	40-13				
67244-95600-000	40-14				
67245-95600-000	40-15				
67251-99E10-000	40-16				
67252-95600-000					

00000

90000

PART NO.	FIG.NO.-REF.NO.	PART NO.	FIG.NO.-REF.NO.	PART NO.	FIG.NO.-REF.NO.
09103-06125-000	33-7 34-7 35-7		27-19 28-19	09181-20167-000	20-13-2 20-12-5 20-13-3
09103-06237-000	34-14 35-14 37-14	09160-05501-000 09160-06082-000	19-5 15-12 22-11 41-24	09181-20172-000 09181-20176-000	20-13-4 20-13-5 23-19
09103-06281-000	24-8 25-6 5-11	09160-06085-000	34-15 35-15 37-15	09202-04016-000 09202-06015-000 09204-01002-000	20-16 24-11 18-13 23-15
09106-02001-000	5-17	09160-06104-000	40-41		
09108-06126-000	15-9		41-18		23-20
09108-06146-000	15-9	09160-06145-000	41-18	09204-03003-000	25-25
09108-08092-000	24-15	09160-08082-000	23-18	09205-02004-000	19-6
09108-08130-000	41-3			09205-06007-000	22-6
09116-06094-000	23-12			09206-11006-000	24-16
09116-06099-000	23-8	09160-08091-000	41-19		25-8
09116-06189-000	24-7	09160-10082-000	22-12	09248-10008-000	4-13
09116-06225-000	15-10 25-19 26-10 27-10	09160-10088-000 09160-10089-000 09160-10090-000	20-6-1 20-6-2 20-6-3		24-6 25-9 24-12
	28-10	09160-10091-000	20-6-4	09248-12007-000	24-12
09116-06227-000	18-10	09160-10092-000	20-6-5	09250-06005-000	26-4
09116-06229-000	15-19	09160-12070-000	20-10-2		27-4
09116-08150-000	26-11 27-11 28-11	09164-08017-000 09166-12L01-000 09167-23001-000	41-20 20-7 25-13	09250-12004-000	26-5 27-5 28-5
09116-08156-000	25-5 32-10	09168-10022-000	4-12	09250-12006-000	26-15
09118-06123-000	32-11		24-9	09262-12001-000	25-15
09125-05132-000	26-18 27-17 28-17	09168-12017-000 09168-32001-000	24-10 33-6	09262-20106-000	25-3
09126-05003-000	40-39		34-6	09262-25003-000	4-3
09126-06015-000	32-12	09169-06088-000	33-8	09280-05008-000	19-7
09128-06014-000	18-11		34-8	09280-15007-000	4-10
09136-05041-000	32-13		35-8	09280-16005-000	19-8 18-14
09140-05005-000	26-19 27-18 28-18	09180-06097-000 09180-06310-000	41-25 6-6 7-6	09280-20004-000 09280-27006-000	32-17 12-7 13-7 14-7
09140-06020-000	40-40		8-6	09280-49002-000	25-20
09140-06021-000	5-18	09180-06357-000	22-13	09282-10008-000	15-17
09140-08023-XCO	25-10 32-14	09181-10156-000 09181-12008-000	20-2 20-10-1	09282-12L05-000	25-14
09148-06008-000	32-15	09181-12111-000	20-10-3	09283-10L01-000	4-6
09159-06079-000	41-16 41-17		20-11	09283-25098-000	4-2
09159-08059-000	41-4	09181-20159-000	20-12-1	09283-25L04-000	4-7
09159-10L07-000	22-10	09181-20160-000	20-12-2	09306-08002-000	41-21
09159-12059-000	21-4	09181-20162-000	20-12-3	09306-08016-000	32-18
09160-05029-000	26-20	09181-20164-000	20-12-4	09308-08011-000	26-12 27-12 28-12

PART NO.	FIG.NO.-REF.NO.	PART NO.	FIG.NO.-REF.NO.	PART NO.	FIG.NO.-REF.NO.
09320-04010-000	24-13	09492-34004-000	9-15-2		
09320-09039-000	33-9 34-9 35-9		10-15-3 11-15-1 9-15-3		
09321-05019-000	36-8	09492-36L01-000	9-15-3		
09343-50L01-040	12-8 13-8 13-9 14-8 14-9	09492-38L01-000 09493-21L01-000 09493-22L01-000 09493-23L01-000 09493-95L01-000	11-15-2 11-15-3 11-17 9-17 10-17 9-18		
09343-50L01-300	12-10 13-12 14-12		10-18 11-18 29-8		
09355-50105-600	9-30 10-30 11-30	09800-01007-000	30-8 31-8		
09367-06007-000	13-13 14-13				
09380-10003-000	20-4				
09381-18002-000	5-4				
09383-04002-000	18-15				
09401-11422-000	13-15 14-15				
09401-11424-000	1-9 2-9 3-9				
09403-07325-000	41-29				
09403-12314-000	41-30				
09404-06429-000	36-18				
09404-06435-000	36-9				
09407-10404-000	21-15				
09420-03002-000	15-15				
09440-05039-000	20-17				
09440-24007-000	20-18				
09481-20001-000	36-6				
09482-00L04-000	1-16 2-16 3-16				
09491-50L01-000	9-3-1				
09491-52L01-000	9-3-2				
09491-54L01-000	9-3-3				
09491-62009-000	10-3-1				
09491-64003-000	10-3-2				
09491-66005-000	10-3-3 11-3-3				
09491-68006-000	11-3-1				
09491-70018-000	11-3-2				
09492-30018-000	10-15-1				
09492-32011-000	9-15-1 10-15-2				

SUZUKI **DF4/5/6** PARTS CATALOGUE

SUZUKI MOTOR CORPORATION All rights reserved

No part of this document may be reproduced or transmitted in any form or by any means, electronic or mechanical, for any purpose, without the express written permission of Suzuki Motor Corporation.

SUZUKI MOTOR CORPORATION
Technical Readiness Group, Quality Administration Department
300 Takatsuka, Minami, Hamamatsu, Japan

Reprint Prohibited

SUZUKI MOTOR CORPORATION